



ECHELON

DIAMOND SERIES

BUILT-IN OUTDOOR GAS GRILL
E660i, E790i, and E1060i

INSTALLATION INSTRUCTIONS
AND OWNER'S MANUAL

INSTALLER: Leave these instructions with consumer.
CONSUMER: Retain for future reference.



E790i shown

IMPORTANT: READ THESE INSTRUCTIONS CAREFULLY BEFORE STARTING INSTALLATION OR USE.

WARNINGS AND SAFETY CODES

⚠ DANGER:
IF YOU SMELL GAS:

1. Shut off the gas to the appliance.
2. Extinguish any open flame.
3. Open lid.
4. If odor continues, keep away from the appliance and **immediately** call your gas supplier or the fire department.

⚠ WARNING:

1. Do not store or use gasoline or other flammable vapors and liquids in the vicinity of this or any other appliance.
2. An LP cylinder not connected for use shall not be stored in the vicinity of this or any other appliance.

CODE AND SUPPLY REQUIREMENTS: This grill must be installed in accordance with local codes and ordinances, or, in the absence of local codes, with the latest *National Fuel Gas Code (ANSI Z223.1/NFPA 54)*, or *Natural Gas and Propane Storage and Handling Installation Code (CSA-B149.1)*.

⚠ WARNING:
Improper installation, adjustment, alteration, service, or maintenance can cause injury or property damage. For proper installation, refer to the installation instructions. For assistance or additional information, consult a qualified professional service technician, service agency, or the gas supplier.

This appliance and its dedicated manual shutoff valve must be disconnected from the gas-supply piping system when testing the system at pressures in excess of ½ psig (3.5 kPa).

All electrical outlets in the vicinity of the grill must be properly grounded in accordance with local codes, or, in the absence of local codes, with the *National Electrical Code, ANSI/NFPA 70*, or the *Canadian Electrical Code, CSA C22.1*, whichever is applicable.

This appliance must be isolated from the gas-supply piping system by closing its dedicated manual shutoff valve during any pressure testing of the gas-supply system at pressures up to and including ½ psig (3.5 kPa).

Keep all electrical-supply cords and fuel-supply hoses away from any heated surface.

Proper operation of your grill requires prompt and periodic maintenance. See the CARE & CLEANING section for details.



Certified to: **ANSI Z21.58-2015**
CSA 1.6-2015

- INSTALLATION INSTRUCTIONS ET MANUEL DU PROPRIÉTAIRE -

GRIL EXTÉRIEUR D'ÎLE DE GAZ D'ÉCHELON

IMPORTANT: LISEZ CES INSTRUCTIONS SOIGNEUSEMENT AVANT DE COMMENCER L'INSTALLATION OU L'UTILISATION

SÛRETÉ ET CODES D'AVERTISSEMENT

▲ DANGER:

SI VOUS SENTEZ LE GAZ :

1. Coupez le gaz à l'appareil.
2. Éteignez-vous n'importe quelle flamme nue.
3. Ouvrez le couvercle si équipé d'un four.
4. Si l'odeur continue, gardez loin de l'appareil et appelez immédiatement votre département de fournisseur ou de feu de gaz.

CONDITIONS DE CODE ET D'APPROVISIONNEMENT:

Ce gril doit être installé selon des codes et des ordonnances locaux, ou, en l'absence des codes locaux, avec l'un ou l'autre le plus défunt *Code national de gaz de carburant* (norme ANSI Z223.1/NFPA 54), et *Stockage de gaz naturel et de propane et manipulation du code d'installation* (CSA-B149.1).

Cet appareil et ses différents robinets d'isolement doivent être démontés du gaz-fournissent le système sifflant en examinant le système aux pressions au-dessus du ½ psig (kPa 3.5).

Cet appareil doit être isolé dans gaz-fournissent le système sifflant par fermeture que ses différents robinets d'isolement manuels pendant tous les essais sous pression du gaz-fournissent le système aux pressions jusques et y compris le ½ psig (kPa 3.5).

- Ce gril est pour utilisation à l'extérieur seulement. Si l'appareil est entreposé à l'intérieur, enlever les bouteilles et les laisser à l'extérieur.
- Ne pas ranger le gril immédiatement après l'avoir utilisé. le laisser refroidir avant de le déplacer ou de la ranger. Le non respect de cette mesure de sécurité pourrait entraîner un incendie causant des dommages à la propriété, des blessures ou la mort.
- Ne pas utiliser cet appareil sous une surface combustible.
- Ne pas utiliser cet appareil sous un auvent. Le non respect de cette mesure de sécurité pourrait entraîner un incendie ou des blessures.
- Dégagement minimal entre les parois latérales et l'arrière de l'appareil et la construction combustible (45.7 cm à partir des parois latérales et 45.7cm à partir de l'arrière).
- Le régulateur de pression de gaz prévu avec cet appareil de cuisson à gaz pour l'extérieur doit être utilisé. Ce régulateur est réglé pour une pression de sortie de 5 pouces de colonne de l'eau pour le gaz naturel, et 10 pouces pour le propane.
- LE RÉGULATEUR INCLUS D'APPAREILS EST ÉVALUÉ POUR LE MAXIMUM DE 1/2 (LIVRES PAR POUCE CARRÉ). SI VOTRE OFFRE DE GAZ EST 1/2 PLUS GRAND QUE (LIVRES PAR POUCE CARRÉ), UN RÉGULATEUR ADDITIONNEL DOIT ÊTRE INSTALLÉ AVANT LE GRIL. VOIR LA SECTION DE CONDITIONS

▲ AVERTISSEMENT:

1. Ne stockez pas ou n'employez pas l'essence ou d'autres vapeurs et liquides inflammables à proximité de ceci ou d'aucun autre appareil.
2. Un cylindre de propane non relié pour l'usage ne sera pas stocké à proximité de ceci ou d'aucun autre appareil.

▲ AVERTISSEMENT:

L'installation inexacte, l'ajustement, le changement, le service, ou l'entretien peuvent causer des dommages ou des dégâts matériels. Référez-vous à ce manuel. Pour de l'aide ou des renseignements supplémentaires, consultez un technicien professionnel qualifié de service, une agence de service ou le fournisseur de gaz.

Toutes les sorties électriques à proximité du gril doivent être correctement fondues selon des codes locaux, ou en l'absence de local code, avec le code électrique national, ANSI/NFPA 70, ou le code électrique canadien, CSA C22.1, celui qui est applicable.

Maintenez tout électrique-fournissent des cordes et carburant-fournissent des tuyaux partis de n'importe quelle surface de chauffage.

D'OFFRE DE GAZ POUR LA PRESSION APPROPRIÉE D'OFFRE DE GAZ.

- Ne couvrez jamais la surface entière de cuisine ou de gril de gauffreuses ou de casseroles. La surchauffe se produira et les brûleurs ne seront pas très performants quand la chaleur de combustion est emprisonnée au-dessous de la surface à cuire.
- Ne pulvérisez jamais l'eau sur une unité chaude de gaz, comme ceci peut endommager des composants de porcelaine ou de fer de fonte.
- Une fuite de GPL peut causer un incendie ou une explosion si enflammée entraînant des blessures corporelles graves ou la mort.
- Communiquez avec le fournisseur de GPL pour les réparations ou pour disposer de qules bouteille ou du GPL non utilisé.

Certifié à la norme ANSI : Z21.58-2015 / CSA 1.6-2015

INSTALLATEUR : Laissez ces instructions avec le consommateur.
CONSOMMATEUR : Maintenez pour la future référence.

CONTENTS

GETTING STARTED

ELECTRICAL SAFETY	3
REPLACEMENT PARTS LIST	4
MODEL SPECIFICATIONS.....	7
<i>COUNTERTOP OVERHANG</i>	7
<i>MODEL SPECIFICATIONS TABLE</i>	7
<i>SUBSTRATE</i>	8
<i>BUILT-IN GRILL DIMENSIONS TABLE</i>	8
<i>BUILT-IN GRILL WIRING DIAGRAM</i>	9
GRILL MAINTENANCE AND SAFETY INFORMATION	10
<i>ELECTRICAL CONNECTIONS</i>	10
INSTALLATION REQUIREMENTS	11
<i>OVERHEAD CONSTRUCTION AND EXHAUST HOOD REQUIREMENTS</i>	11
<i>SIDE AND REAR WALL CLEARANCES</i>	12
<i>BACKSPLASH CLEARANCE (IF APPLICABLE)</i>	12
<i>ENSURE PROPER COMBUSTION AIR AND COOLING AIRFLOW</i>	13
<i>GAS-SUPPLY PLUMBING REQUIREMENTS</i>	13
ENCLOSURE REQUIREMENTS.....	14
<i>VENTILATION (ALL ENCLOSURES)</i>	14
<i>WHEN A PROPANE (L.P.) CYLINDER IS USED IN THE ENCLOSURE</i>	14
PROPANE SAFETY INFORMATION	15
<i>WARNING</i>	15
<i>INSTALLATION SAFETY GUIDELINES</i>	15
OPERATING THE UNIT SAFELY AND CORRECTLY	15
SAFE USE & MAINTENANCE OF PROPANE GAS CYLINDERS	17

INSTALLATION

INSTALLATION	18
<i>COUNTER PREPARATION</i>	18
<i>CONNECT THE GAS SUPPLY</i>	18
<i>INSTALL ZONE DIVIDERS</i>	19
ELECTRICAL INSTALLATION	21

USE, CARE, & SERVICE

IDENTIFICATION OF GRILL CONTROLS	22
LIGHTING (IGNITION) INSTRUCTIONS.....	23
<i>ELECTRONIC LIGHTING</i>	23
<i>MANUAL LIGHTING</i>	23
<i>SHUTTING OFF THE UNIT</i>	23
DIGITAL THERMOMETER / INTERIOR AND KNOB LIGHTS.....	25
ROTISSERIE INSTRUCTIONS	28
OPTIONAL INFRARED BURNER OPERATION	29
CHARCOAL/SMOKER BASKET (IF EQUIPPED).....	30
GRILLING TIPS.....	32
CARE & CLEANING	33
REPLACING HALOGEN BULBS	34
POWER SUPPLY FUSE REPLACEMENT	35
CONVERT GAS TYPE / CHECK BURNER ORIFICES	36
BURNER AIR SHUTTER ADJUSTMENT	38
CONTROL PANEL REMOVAL	39
NOTES PAGE	40
TROUBLESHOOTING.....	41
WARRANTY	42

ELECTRICAL SAFETY

To protect against electric shock, do not immerse cord or plugs in water or other liquid.

Unplug from the outlet when not in use and before cleaning. Allow to cool before putting on or taking off parts.

Do not operate any outdoor cooking gas appliance with a damaged cord, plug, or after the appliance malfunctions or has been damaged in any manner. Contact the manufacturer for repair.

Do not let the cord hang over the edge of a table or touch hot surfaces.

Do not use an outdoor cooking gas appliance for purposes other than intended.

When connecting, first connect plug to the outdoor cooking gas appliance then plug appliance into the outlet.

Use only a properly wired and inspected 120VAC (15 AMP minimum) Ground Fault Circuit Interrupter (GFCI) GROUNDING 3-wire receptacle with this outdoor cooking gas appliance.

The GFCI receptacle must be a WEATHER-PROOF IN-USE COVERED RECEPTACLE.

Never remove the grounding plug or use with an adapter of 2 prongs.

Use only extension cords with a 3 prong grounding plug, rated for the power of the equipment, and approved for outdoor use with a W-A marking.

The provisions of the National Electric Code as well as any local codes must be observed when installing the product.

REPLACEMENT PARTS LIST

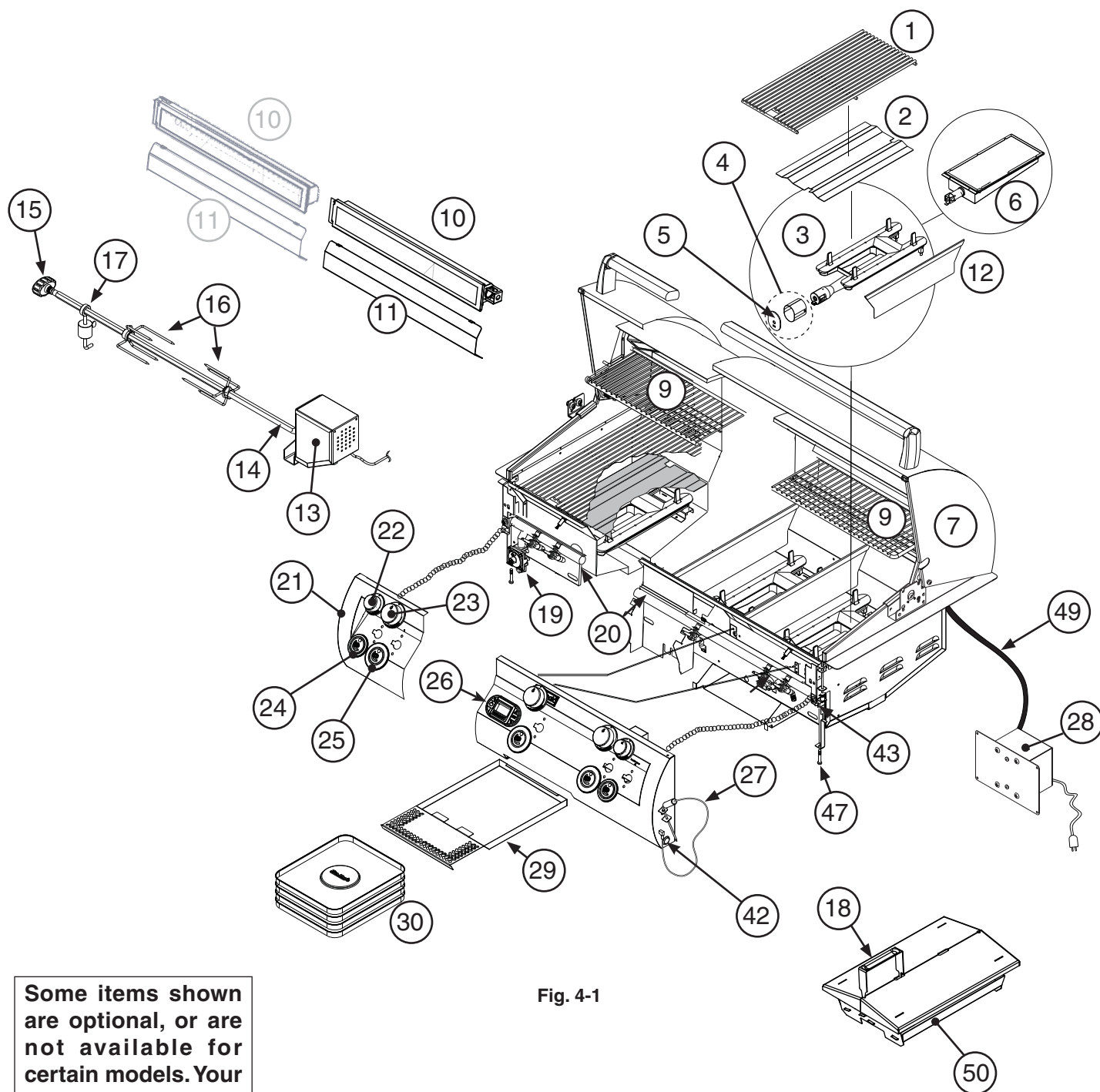

Fig. 4-1

Some items shown are optional, or are not available for certain models. Your model may vary, refer to parts list table.

To order replacement parts, contact your local Fire Magic® dealer.

Items in light gray are not available on all models.

REPLACEMENT PARTS LIST (Cont.)

Item	Description	E660i		E790i		E1060i	
		Part No.	Qty.	Part No.	Qty.	Part No.	Qty.
1.	Stainless cooking grid (set of 2 or 3)	3544-DS-3	1	3539-DS-3	1	23539-DS-2	2
2.	Flavor grid (set of 3 or 4)	3057-S-3	1	3056-S-3	1	3056-S-4	1
3.	Main burner	3041-50	3	3041-50	3	3041-50	4
4.	Heatshield kit	24177-05	3	24177-05	3	24177-05	4
5.	Silicone gasket	24177-06	3	24177-06	3	24177-06	4
6.	Infrared burner *	3050	1	3050	1	3050	1
7.	Oven lid	23738-53	1	23745-53	1	23747-53	1
or	Oven lid w/ window	24193-54	1	24188-54	1	24183-54	1
8.	Window (only) *‡	24187-45	1	24187-45	1	24187-45	1
9.	Warming rack	3673S-M	1	3675S-M	1	3674S-M	1
10.	Back burner assembly	24794-02	1	24789-02	1	24794-02	2
11.	Back burner cover	24794-010	1	24789-010	1	24784-010	2
12.	Zone separator	3061-S	2	3061-S	2	3061-S	3
13.	Heavy-duty rotisserie motor	3600-05M	1	3600-05M	1	3600-05M	1
14.	Heavy-duty rod	3606-40	1	3609-40	1	3607-40	1
15.	Heavy-duty rod knob	24187-16	1	24187-16	1	24187-16	1
16.	Meat holder (pair)	3613	1	3613	1	3613	1
17.	Counterbalance	3620E	1	3620E	1	3620E	1
18.	Grid/smoker lid lifter	3519	1	3519	1	3519	1
19.	Convertible regulator	PR-4	1	PR-4	1	PR-4	1
20.	Valve manifold w/ back burner	24193-23	1	24188-23	1	24183-23	1
21.	Control panel w/ back burner and raceway	24194-13	1	24189-13	1	24184-13	1
or	Control panel w/ back burner, raceway, and wire harness	24194-16	1	24189-16	1	24184-16	1
22.	Small knob	24182-42	1	24182-42	1	24182-42	2
23.	Large knob	24182-41	3	24182-41	3	24182-41	4
24.	LED disk (small)	24182-64	1	24182-64	1	24182-64	2
25.	LED disk (large)	24182-63	3	24182-63	3	24182-63	4
26.	Digital thermometer	24182-12	1	24182-12	1	24182-12	1
27.	Meat probe	24187-14S	1	24187-14S	1	24187-14S	1
28.	Power supply w/ connector	24187-18	1	24187-18	1	24187-18	1

* If equipped

‡ Not shown

REPLACEMENT PARTS LIST (Cont.)

Item	Description	E660i		E790i		E1060i	
		Part No.	Qty.	Part No.	Qty.	Part No.	Qty.
29.	Drip tray	3087	1	3087	1	3087	2
30.	Drip tray liner (set of 4)	3557	1	3557	1	3557	1
31.	Wire harness w/ raceway ‡	24194-48	1	24189-48	1	24184-48	1
32.	Back burner electrode *‡	4199-52	1	4199-52	1	4199-52	2
33.	Main burner electrode ‡	3199-72	3	3199-72	3	3199-72	4
34.	Thermometer wire harness ‡	24187-13	1	24187-13	1	24187-13	1
35.	Natural gas orifice(s) ‡	3001-42-3	1	3001-38-3	1	3001-40-4	1
36.	Natural back burner gas orifice(s) ‡	3001-53-1	1	3001-51-1	1	3001-53-2	1
37.	Propane gas orifice(s) ‡	3001-54-3	1	3001-53-3	1	3001-53-4	1
38.	Propane back burner gas orifice(s) ‡	3001-63-1	1	3001-57-1	1	3001-63-2	1
39.	12V / 10 watt halogen light bulb ‡	24187-15	2	24187-15	2	24187-15	3
40.	Light lens ‡	24187-26	2	24187-26	2	24187-26	3
41.	Lamp assembly ‡	24187-28	2	24187-28	2	24187-28	3
42.	Lighted master shut-off switch	24182-46	1	24182-46	1	24182-46	1
43.	Light micro switch	24187-20	1	24187-20	1	24187-20	1
44.	Flash tube (left) ‡	24187-29	1	24187-29	1	24187-29	1
45.	Flash tube (right) ‡	24187-35	2	24187-35	2	24187-35	3
46.	Backburner flex connector ‡	3030-08	1	3030-08	1	3030-08	2
47.	Support screw (set of 2)	24182-47	1	24182-47	1	24182-47	1
48.	Fire Magic® cookbook ‡	3595	1	3595	1	3595	1
49.	Wire harness extension	24182-53	1	24182-53	1	24182-53	1
50.	Charcoal / smoker basket *	3564-2	1	3564-2	1	3564-2	1

* If equipped

‡ Not shown

MODEL SPECIFICATIONS

MODEL SPECIFICATIONS TABLE

Table 1	E660i	E790i	E1060i
Main burner quantity	3	3	4
N/P orifice drill size	#42 / #54	#38 / #53	#40 / #53
Back burner quantity	1	1	2
N/P orifice drill size	#53 / #63	#51 / #57	#53 / #63
Infrared searing burner [▲]			
N/P orifice drill size	#45 / #55	#45 / #55	#45 / #55
Echelon insulating liner model # (not included)*	3176-51	3186-51	3185-51
Wind deflector model # (not included)	23732-18	23745-18	23747-18
Burner maintenance kit model # (not included)	MK-1	MK-1	MK-1
Input electrical requirements	120VAC / 15 AMP minimum / 60 Hz / GFCI outlet		
Oven Lights Rating	12V / 10 watt halogen light bulb		
A Countertop to unit bottom cut-out*	12"	12"	12"
B Side to side non-combustible cut-out*	31-1/4"	37"	50"
C Front to back non-combustible cut-out*†	23-1/2"	23-1/2"	23-1/2"
D Control panel width non-combustible cut-out‡	33"	38-3/4"	51-3/4"

▲ If equipped

* **Note:** If installing this grill in a combustible enclosure, the correct insulating liner must be used. Consult liner instructions for counter cut-out dimensions and installation.

† Includes any substrate at front wall of enclosure (in the area the rear of the control panel is to sit flush against). See [SUBSTRATE section on next page](#).

‡ Only applicable for non-combustible enclosures that have countertops with an overhang (see illustration and section below).

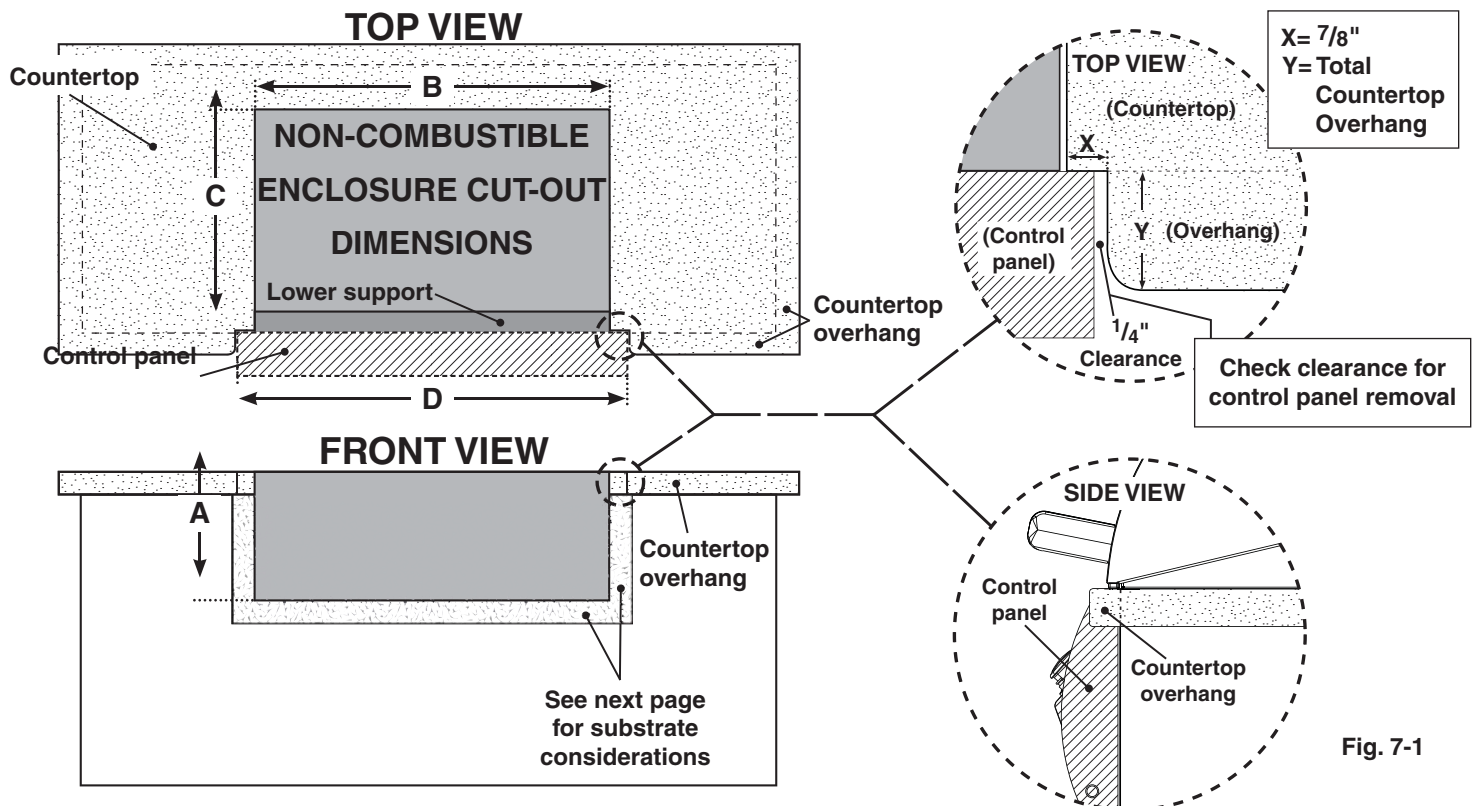

Fig. 7-1

COUNTERTOP OVERHANG

The control panel is designed to sit flush against the enclosure front wall. If the **non-combustible enclosure** countertop extends beyond the front wall, creating a countertop overhang, it must be cut flush with the front wall for the width of the control panel or a gap will be created exposing the forward portions of the left and right side grill fire walls. See illustrations above.

Important: FOR YOUR SAFETY, you must provide openings in the island enclosure for drainage, replacement air, and cross-ventilation of any storage area exposed to possible leakage from gas connections, the unit, or propane tanks. See the ENCLOSURE REQUIREMENTS section for details.

SUBSTRATE

When adding any substrate to the enclosure front wall (including tiles, stone, etc.), consider the following:

Substrate Behind Control Panel

Substrate + countertop "front to back" cutout must equate to **Dim. C** (see previous page) when the substrate sits flush behind the control panel.

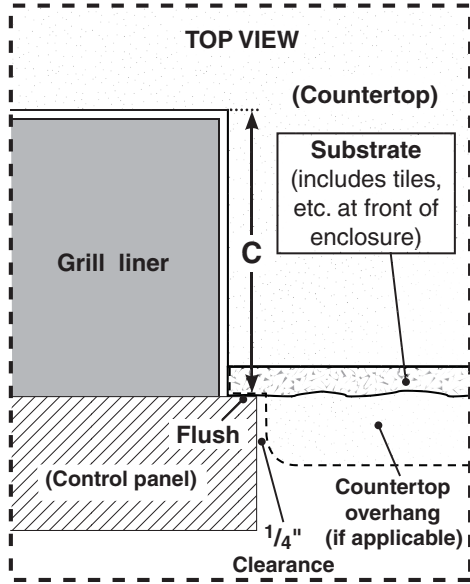

Fig. 8-1

Substrate Alongside Control Panel

Any additional substrate alongside the control panel does not need to be considered in **Dim. C** (see previous page), however a 1/4" clearance on each side (same as overhang) and below is required.

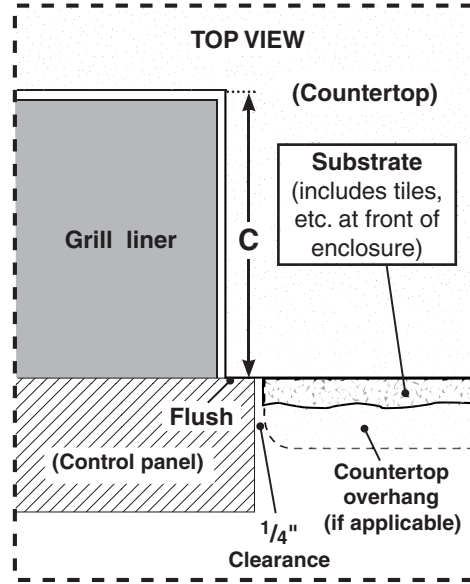

Fig. 8-2

BUILT-IN GRILL DIMENSIONS TABLE

Model	Height		Width		Depth
	(Top to bottom)		(Left to right)		(Front to back)
	Open (E)	Closed (F)	Hanger to hanger (G)	Control panel width (H)	Maximum depth (I)
E660i	23-5/8"	15"			
E790i	23-5/8"	15"	42"	38-1/4"	29-3/4"
E1060i	23-5/8"	15"	54-7/8"	51-1/4"	29-3/4"

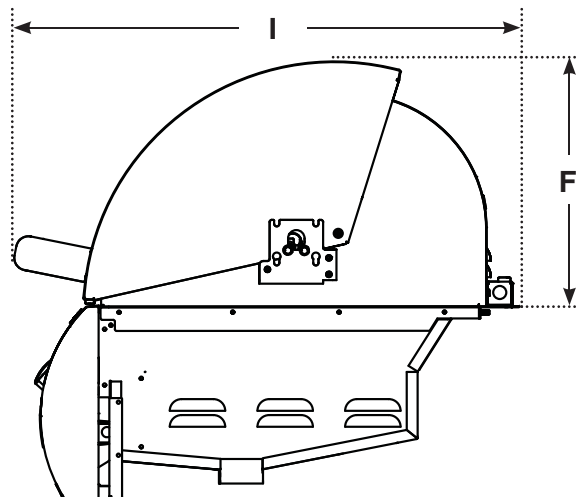
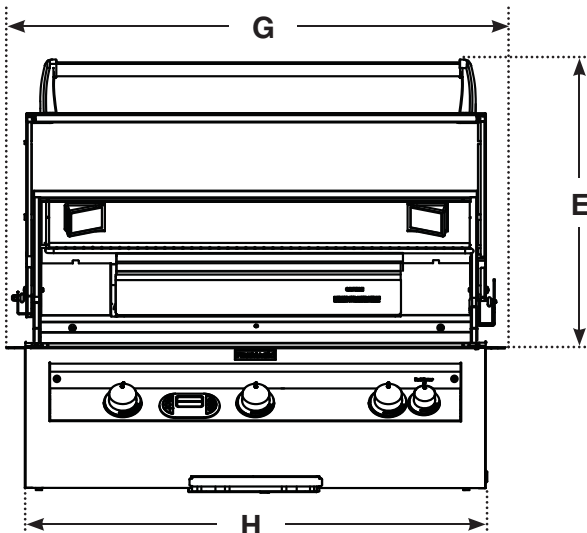
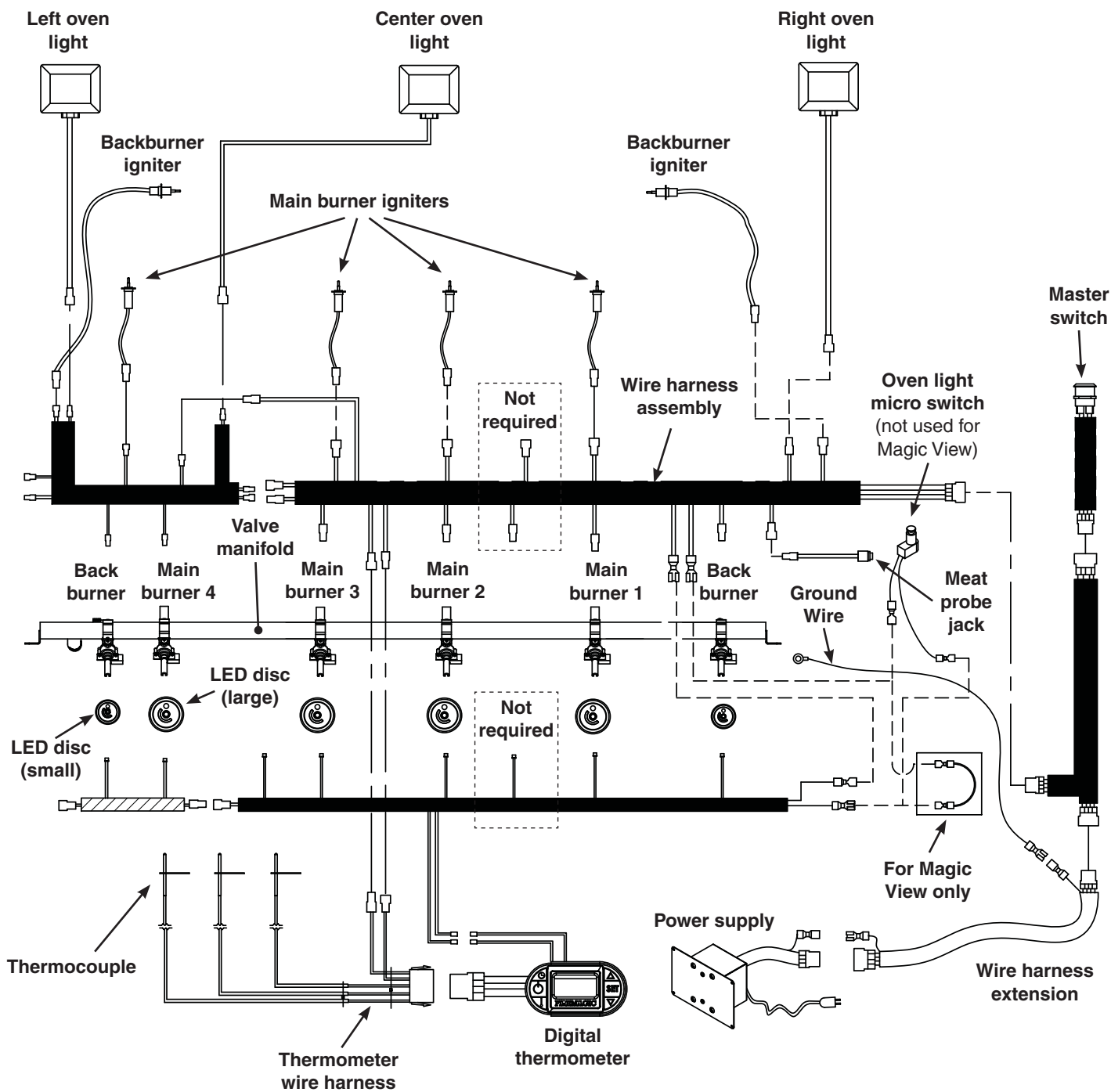

Fig. 8-3

BUILT-IN GRILL WIRING DIAGRAM *



* E1060i model shown. Model wire diagrams may vary.

Note: In addition, a wire diagram specific to your unit can be found affixed to the inside of the control panel.

GRILL MAINTENANCE AND SAFETY INFORMATION

1. The outdoor grill and surrounding area **MUST** remain clear of flammable substances such as gasoline, yard debris, wood, etc.
2. The airflow through the vent space located below the control panel must remain unobstructed.
3. **When using propane gas:**
 - a. **The required ventilation openings in the enclosure must be clear of debris. See the PROPANE SAFETY INFORMATION section.**
 - b. **The propane cylinder, regulator, and rubber hose must be in a location not subject to temperature above 125° F (51° C).**
4. The back burner or IR burner cover must be removed before using the burner.
5. The flames on each burner burn evenly along the entire burner with a steady flame (mostly blue). If burner flames are not normal, check and clean the orifice and burner/venturi tubes for insects and insect nests. A clogged tube can lead to a fire beneath the grill. A proper flame pattern will ensure safe operation and optimal performance. Adjust the air shutter as needed (see AIR SHUTTER ADJUSTMENT).
6. The in-line gas valve or gas cylinder valve must always be shut OFF when the grill is not in use.
7. The drip collector holes must be clear and unobstructed. Excessive grease deposits can result in a grease fire.
8. Whenever reconnecting any wires, apply a small amount of dielectric grease to the male connector, then make the connection. This will ensure conductivity and prevent moisture from affecting the contact.

IMPORTANT

IN THE EVENT OF A GREASE FIRE, IMMEDIATELY SHUT OFF THE MAIN GAS VALVE TO THE UNIT. KEEP THE LID OPEN AND ALLOW THE FIRE TO EXTINGUISH ITSELF. A THOROUGH INSPECTION BY A TRAINED SERVICE TECHNICIAN SHOULD BE CONDUCTED BEFORE FUTURE USE OF YOUR UNIT. THE SERVICE TECHNICIAN WILL CHECK THE SYSTEM FOR GAS LEAKS AND WILL CHECK ALL ELECTRICAL WIRING FOR DAMAGE. ALL GAS LEAKS AND WIRING MUST BE REPAIRED PRIOR TO FUTURE USE.

WARNING: NEVER cover the *entire* cooking or grill surface with griddles or pans. Overheating will occur, and burners will not perform properly when combustion heat is trapped below the cooking surface.

CAUTION: NEVER spray water on a hot gas unit.

The grill serial number tag can be found affixed to the grill body behind the control panel (on an aluminum tag) and on the underside of the drip tray handle (on a thermal label). It is recommended that the drip tray first be removed and cleaned / emptied of its contents, then turned over to view. The unit rating label is located inside of the control panel.

ELECTRICAL CONNECTIONS

A 120VAC (15 AMP minimum) GFCI GROUNDED 3-wire receptacle (not included) is required within the vicinity of the grill to provide power to the unit. The GFCI receptacle must be a WEATHER-PROOF IN-USE COVERED RECEPTACLE.

- **Observe the National Electric Code and all local codes.**
- **Verify proper polarity of the receptacle.**
- **If an extension cord is used, ensure it is a 3-wire GROUNDED cord that is rated for the power of the equipment, and is approved for outdoor use with a W-A marking. DO NOT use 2-prong adapters.**
- **DO NOT TAMPER WITH THE EXTENSION CORD OR THE UNIT POWER-SUPPLY CORD.**

Important: ONLY REPLACE THE OVEN LIGHTS WITH 12V / 10 WATT HALOGEN BULB(S).

INSTALLATION REQUIREMENTS

Installation must be performed by a qualified professional service technician.

This grill is designed for outdoor use only. **DO NOT** use this grill inside a building, garage, or enclosed area. **DO NOT** use this grill in or on a recreational vehicle or boat.

When installing this grill in a combustible surround, an RHP insulating liner must be used.

The grill must have a minimum clearance of 18" from combustible materials/items in all directions.

OVERHEAD CONSTRUCTION AND EXHAUST HOOD REQUIREMENTS

A minimum 5 foot clearance is required between the countertop and the overhead construction.

When installed under combustible overhead construction, the area above the cooking surface of the grill **must** be covered with an exhaust hood. The exhaust hood provides the protection for the combustible overhead construction. See exhaust hood information below and Fig. 11-1.

Important: **DO NOT** use this appliance under **unprotected** combustible overhead construction.

When installed under overhead non-combustible construction, an exhaust hood is highly recommended; see exhaust hood information below and Fig. 11-1.

Exhaust Hood

When using an exhaust hood, the area above the cooking surface of the grill must be covered with a hood larger than the cooking area of the grill, and with a minimum of 1200 CFM (cubic feet per minute) for proper outdoor application.

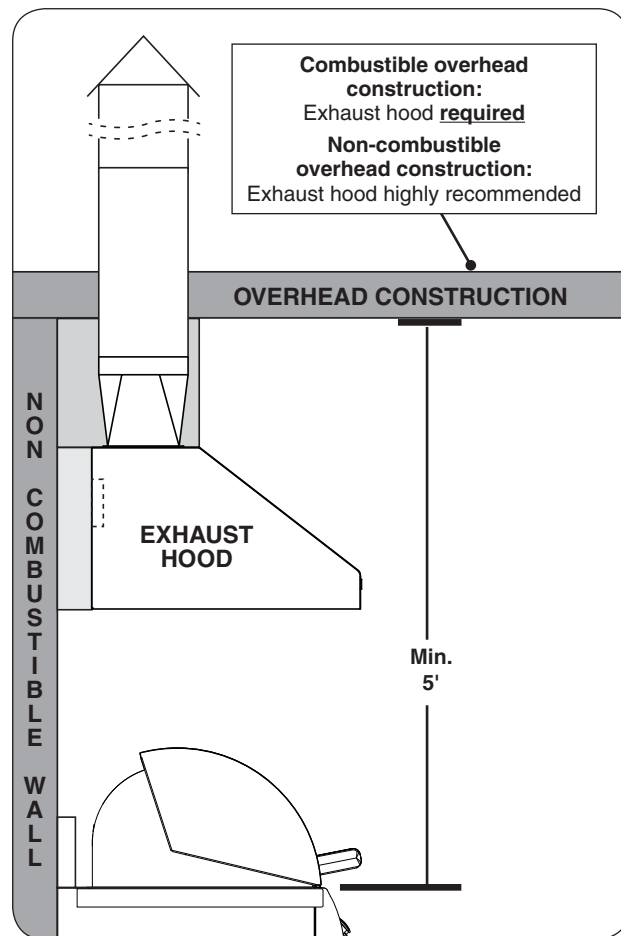

Fig. 11-1 Overhead requirements

SIDE AND REAR WALL CLEARANCES

For the minimum clearances between the grill and any side or rear walls, your setup must fall within one (or more) of the following:

A. Clearance between grill and strictly non-combustible wall

(i.e. brick wall, see Fig. 12-1)

- The grill must have a minimum of 4" right, left, and rear clearance from any non-combustible wall.

(To allow for proper ventilation and prevent dangerous overheating.)

B. Clearance between grill and a protected combustible wall

(i.e. a non-combustible wall in front of a combustible wall to serve as a barrier. This can be accomplished by brick, or a metal stud finished with non-combustible substrate, see Fig. 12-2)

- The grill must have a minimum of 14" right, left, and rear clearance from the protected combustible wall.

(The 4" non-combustible material plus an additional 10" clearance between the grill and protected wall.)

C. Clearance between grill and combustible wall

- The grill must have a minimum of 18" right, left, and rear clearance from any combustible wall (see Fig. 12-3).

BACKSPLASH CLEARANCE (IF APPLICABLE)

If a non-combustible backsplash exists, it must have a minimum of a 4" clearance from the rear of the grill (to allow for proper ventilation and prevent dangerous overheating). See Fig. 12-4.

Important: This 4" backsplash clearance must first be met prior to any non-combustible walls beginning behind it.

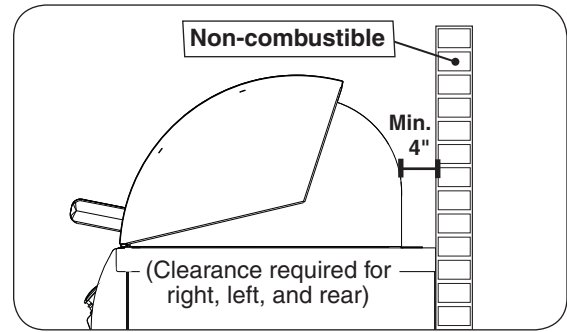

Fig. 12-2 Clearance 'A' Diagram

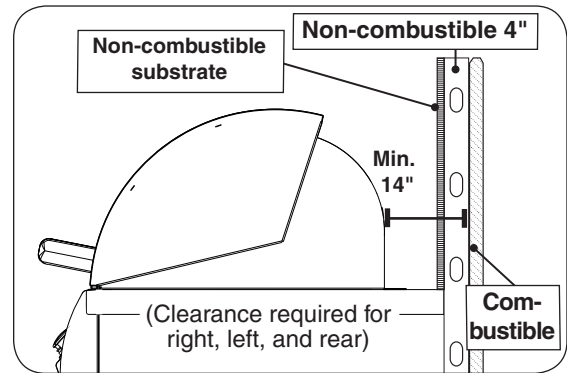

Fig. 12-3 Clearance 'B' Diagram

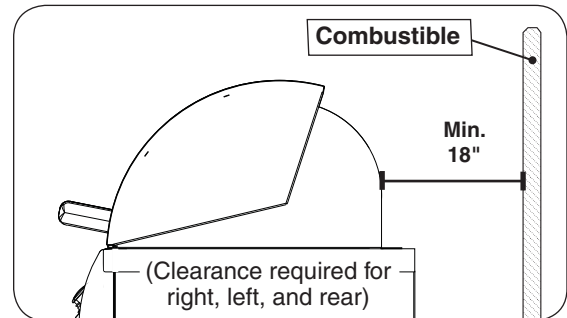

Fig. 12-4 Clearance 'C' Diagram

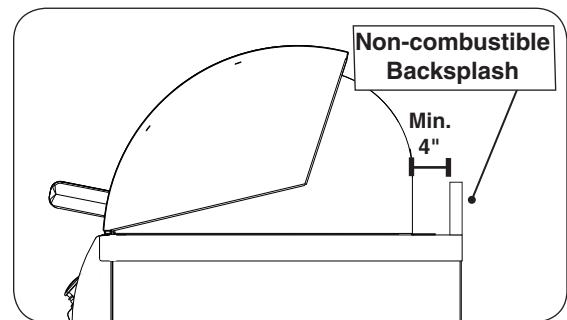

Fig. 12-5 Backsplash clearance

INSTALLATION REQUIREMENTS (Cont.)

The control panel **MUST** remain removable for servicing (see PARTS LIST).

ENSURE PROPER COMBUSTION AIR AND COOLING AIRFLOW

Proper airflow (Fig. 13-1) **MUST** be maintained for the grill to perform as it was designed. If airflow is blocked, overheating and poor combustion will result. Do not block the 1" (2.5 cm) front air inlet along the bottom of the control panel or more than 75% of the cooking grid surface with pans or griddles.

Note: The 1" (2.5 cm) front air space also allows access to the drip tray.

CAUTION: Wind blowing into or across the rear oven lid vent (Fig. 13-2) can cause poor performance and/or dangerous overheating. Orient the grill so that the prevailing wind blows toward the front of the grill (Fig. 13-3). **A wind deflector is available for purchase to assist in proper airflow during windy conditions.** See Table 1 for model numbers. Follow the instructions included with the wind deflector for installation.

GAS-SUPPLY PLUMBING REQUIREMENTS

For natural gas or a household propane system, rigid $1\frac{1}{2}$ " (1.3 cm) or $\frac{3}{4}$ " (1.9 cm) black steel pipe or local code-approved pipe is required to conduct the gas supply to the unit. Contact your local gas supplier. Connect this pipe to the required C.S.A.-approved stainless-steel flex connector (attached). An NPT adapter has been provided for $1\frac{1}{2}$ " pipe. **DO NOT use a rubber hose within the grill enclosure.** Apply only joint compounds that are resistant to all gasses to all male pipe fittings except flare fittings. Make sure to tighten every joint securely.

Note: If $1\frac{1}{2}$ " (1.3 cm) pipe is used with **natural gas**, it should be no longer than 20' (6.1 meters).

Important: **A shut-off valve (not included) in the gas line is required.** It provides for safety when the unit is not in use and for convenient maintenance and repair. It must be installed within 6 feet of the unit. Use a pipe joint compound resistant to all gasses on all male fittings except flare fittings.

GAS SUPPLY AND MANIFOLD PRESSURES:

For **natural gas** - normal 7" (17.78 cm) water column (w.c.), minimum 5" (12.7 cm), maximum $10\frac{1}{2}$ " (26.7 cm). For **propane gas** - normal 11" w.c., minimum 10" (25.4 cm), maximum 13" (33 cm).

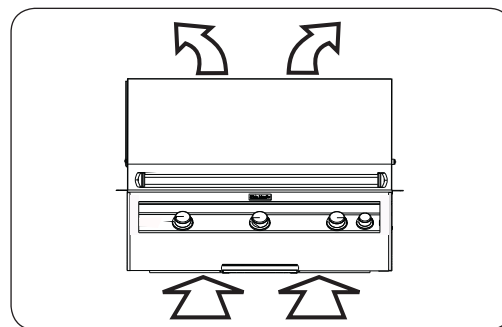

Fig. 13-1 Ventilation diagram

INCORRECT



Fig. 13-2 Airflow direction - INCORRECT

CORRECT



Fig. 13-3 Airflow direction - CORRECT

ENCLOSURE REQUIREMENTS

VENTILATION (ALL ENCLOSURES)

For All Piping Systems and All Gas Types:
(Natural Gas, Household Propane, L.P. Cylinder)

FOR YOUR SAFETY, you must provide the openings listed below for replacement air and cross-ventilation of the unit enclosure.

One side of the enclosure shall be left completely open to the outside; OR 4 (minimum) ventilation openings **MUST** be created (reference Fig. 14-1):

Each opening must have a minimum of **10 sq. in.** of free area. The openings must be equally sized and unobstructed.

Two openings must be in the side walls of the enclosure, at the top level, and spaced at 180 degrees. The openings must begin 1" or less below the countertop level and end no more than 5" below the countertop level.

Two openings must be in the side walls of the enclosure, at the floor level, and spaced at 180 degrees. The openings must begin 1" or less above the floor level and end no more than 5" above the floor level.

To achieve the proper ventilation, you may use RHP venting panels (PN 5510-01) as shown. Contact your dealer.

KEEP THE VENT OPENINGS AND SURROUNDING AREA OF THE ENCLOSURE CLEAN AND FREE OF OBSTRUCTIONS AT ALL TIMES.

WARNING: Ventilation openings in side walls shall not communicate directly with other enclosures of the outdoor cooking gas appliance.

WHEN A PROPANE (L.P.) CYLINDER IS USED IN THE ENCLOSURE

When a propane (L.P.) cylinder is installed inside of the enclosure, the guidelines below **MUST** be followed. FAILURE TO DO SO MAY CAUSE DAMAGE TO YOUR UNIT AND/OR PERSONAL INJURY. Reference Fig. 14-2 for an example.

- Only a C.S.A. listed stainless steel connector can be connected to the grill.
- The regulator/hose assembly coming from the propane cylinder can only be connected to the above mentioned grill flex connector. **DO NOT connect the regulator/hose assembly directly to the grill.** An adapter will be required.
- A non-combustible heatshield must be installed to protect the regulator/hose assembly and propane cylinder valve.
- **RHP offers propane tank door with tank tray models and a propane tank heatshield that rests directly on the tank to meet the cylinder install requirements. Propane tank door with tank tray shown in Fig. 14-3. Contact your dealer for ordering information.**

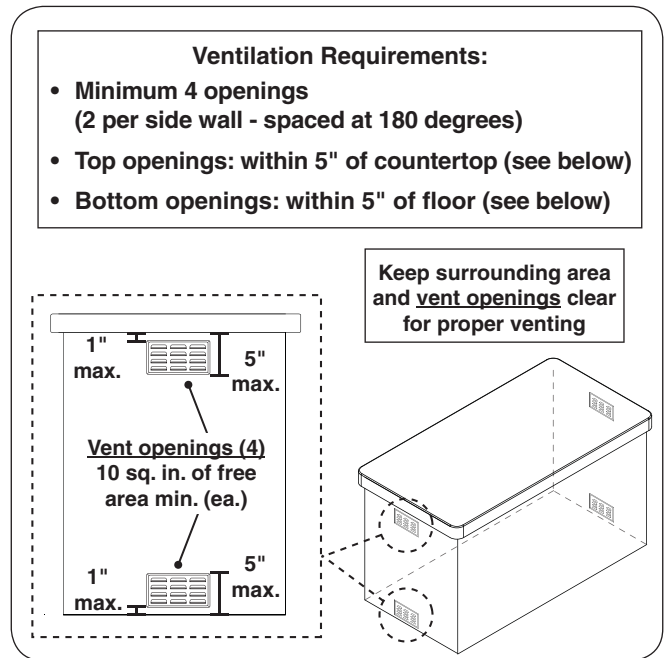

Fig. 14-1 Ventilation detail

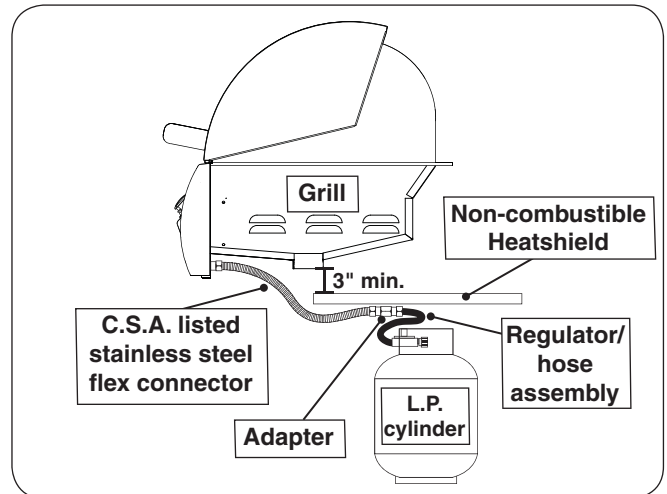

Fig. 14-2 Propane cylinder orientation

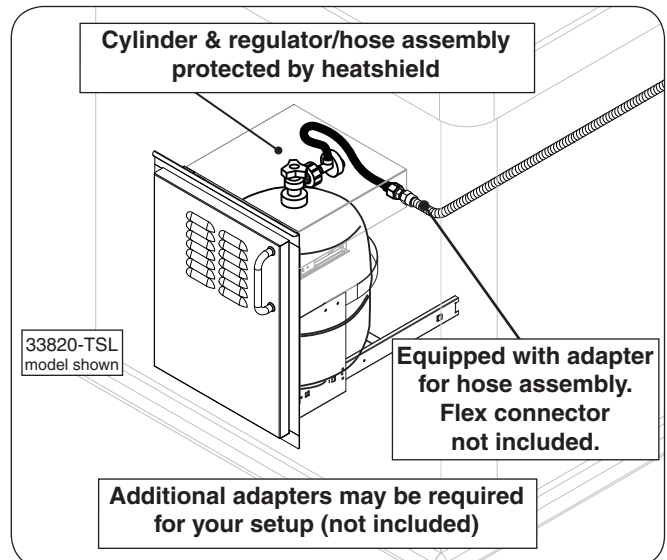

Fig. 14-3 Optional RHP door w/ tank tray

WHEN OPERATING THIS APPLIANCE WITH PROPANE, ALL INSTRUCTIONS AND WARNINGS MUST BE OBSERVED. FAILURE TO DO SO MAY RESULT IN A FIRE OR EXPLOSION CAUSING SERIOUS INJURY OR DEATH.

WARNING

This gas appliance, its enclosure, and the propane cylinder enclosure, if any, **MUST** be plumbed and vented in accordance with local building and safety codes and should be approved by local code enforcement officials. This appliance **MUST** be installed and operated according to the information below.

FAILURE TO PROPERLY VENT THE ENCLOSURE MAY RESULT IN A FIRE OR EXPLOSION CAUSING SERIOUS INJURY OR DEATH.

When using **propane gas**:

- **Propane gas** (also known as **L.P. gas**) is heavier than air and will accumulate or pool in an inadequately vented enclosure or recessed area.
- A leaking gas connection or valve unintentionally left open will create a hazard.
- If a pool of **propane gas** is ignited, an explosion will occur. Adequate venting at the floor level, or the lowest point where gas could accumulate, will eliminate this danger.

Refer to the **ENCLOSURE REQUIREMENTS** section.

Observe all local codes.

- DO NOT store a spare propane-gas cylinder under or near the enclosure.

INSTALLATION SAFETY GUIDELINES

THIS UNIT MUST BE INSTALLED IN SUCH A MANNER THAT ALL REQUIRED VENT OPENINGS ON THE UNIT ENCLOSURE REMAIN CLEAR AND FREE OF ALL OBSTRUCTIONS AT ALL TIMES AND DURING ALL WEATHER CONDITIONS. See the ENCLOSURE REQUIREMENTS section for details.

Important: FOR YOUR SAFETY, you must provide openings in the enclosure for replacement air and cross-ventilation (in case of possible leakage from gas connections or propane cylinders). See the ENCLOSURE REQUIREMENTS section for details.

The gas cylinder, regulator, and rubber hose must be in a location not subject to temps. above 125° F (51° C).

WHEN A PROPANE CYLINDER IS INSTALLED INSIDE OF THE ENCLOSURE, THE GUIDELINES FOUND IN THE ENCLOSURE REQUIREMENTS SECTION MUST BE FOLLOWED.

OPERATING THE UNIT SAFELY AND CORRECTLY

Every time you use the unit, **make sure that:**

1. The area around the enclosure is clear and free from combustible materials, gasoline and flammable vapors/liquids.
2. There is no blockage of the airflow through the vent openings located on the enclosure.
3. The hose is inspected (if applicable). See SAFE USE & MAINTENANCE OF PROPANE-GAS CYLINDERS section.

DO NOT store any combustible materials, gasoline, and any other flammable vapors/liquids in the vicinity of the unit. Provide adequate clearance for servicing and operation.

UTILISATION SÛRE ET ENTRETIEN DES CYLINDRES DE GAZ DE PROPANE

IMPORTANT POUR VOTRE SÛRETÉ

LISEZ ET SUIVEZ TOUS LES AVERTISSEMENTS ÉQUIPÉS DE VOTRE CYLINDRE DE GAZ DE PROPANE.

En actionnant cet appareil avec un cylindre de gaz de propane ON DOIT observer ces instructions et avertissements.

LE MANQUE DE FAIRE AINSI PEUT AVOIR COMME CONSÉQUENCE UNE INCENDIE OU UNE EXPLOSION SÉRIEUSE.

CYLINDRE ET CONDITIONS ET

CARACTÉRISTIQUES DE CONNECTEUR

- Des cylindres et les valves de gaz de propane doivent être maintenus en bon état et doivent être remplacés s'il y a des dommages évidents au cylindre ou à la valve.
- Ce gril, une fois utilisé avec un cylindre, devrait être relié à un gallon de la norme 5 (20lb.) cylindre de gaz de propane équipé d'un OPD (remplissez au-dessus du niveau le dispositif d'empêchement). L'OPD a été exigé sur tous les cylindres vendus depuis octobre 1.1998 pour empêcher le remplissage excessif.
- Les dimensions de cylindre devraient être approximativement 12"(30.5cm) de diamètre et 18" (45.7cm) hauts. Des cylindres doivent être construits et marqués selon les caractéristiques pour des cylindres de gaz de propane du département des ETATS-UNIS du transport (D.O.T.) ou le niveau national du Canada, du CAN/CSA-B339, des cylindres, des sphères et des tubes pour le transport des marchandises dangereuses.
- Le cylindre doit inclure un collier pour protéger la valve de cylindre et le circuit d'alimentation de cylindre doit être assuré le retrait de vapeur.
- Le régulateur de pression et l'ensemble de tuyau utilisé doivent assortir les spécifications pour le type I par ANSI Z 21.58/CGA 1.6 (voir la figue. 16-1).
- La valve de cylindre de gaz de propane doit être équipée d'un dispositif d'accouplement de raccordement de cylindre, décrit comme type I dans la norme définie dans le e. de paragraphe ci-dessus. Ce dispositif est généralement décrit comme coupleur rapide de fil de point culminant.
- Si votre cylindre de gaz de propane vient avec une prise de la poussière, placez le bouchon anti-poussière sur la sortie de valve de cylindre toutes les fois que le cylindre n'est pas en service.

OPÉRATION DE COUPLEUR RAPIDE

Pour relier le régulateur/hose à l'ajustage de précision de valve de cylindre de gaz de propane: Serrez l'écrou de main sur le régulateur au-dessus de l'ajustage de précision de fil de point culminant sur la valve de cylindre. Tournez l'écrou de

main dans le sens des aiguilles d'une montre pour engager les fils et pour serrer jusqu'à ce que douillettement. L'utilisation des pinces ou de la clé ne devrait pas être nécessaire. Seulement le propane marqué par cylindres doit être employé.

Pour débrancher: Tournez l'écrou de main dans le sens contraire des aiguilles d'une montre jusqu'à isolé (fig. 16-1).

Important: Avant d'employer le gril, et ensuite chaque fois que le cylindre est enlevé et rattaché, examinez tous les raccordements pour déceler les fuites. Arrêtez les valves de gril et ouvrez la valve principale de cylindre, puis vérifiez les raccordements avec de l'eau savonneux. Réparez toutes les fuites avant d'allumer le gril.

ATTENTION: Tournez toujours la valve principale de cylindre de propane au loin après chaque utilisation, et avant de déplacer le gril et le cylindre, ou débrancher l'accouplement. Cette valve doit rester fermée et le cylindre a débranché alors que l'appareil n'est pas en service, quoique l'écoulement de gaz soit arrêté par un dispositif de sûreté quand le coupleur est débranché.

Inspectez soigneusement l'ensemble de tuyau chaque fois avant que le gaz soit allumé. Un tuyau fissuré ou effiloché doit être immédiatement remplacé.

Si l'appareil est stocké à l'intérieur, le cylindre doit être disconnected et a enlevé. Des cylindres Disconnected doivent être stockés dehors, hors de la portée des enfants, avec les prises de valve filettées étroitement installées, et ne doivent pas être stockés dans un bâtiment, le garage, ou n'importe quel autre secteur inclus.

POUR VOTRE SÛRETÉ

- Ne stockez pas un cylindre de gaz disponible de propane dessous ou ne vous approchez pas de cet appareil.
- Ne remplissez jamais cylindre au delà de 80 pour cent de plein.
- SI L'INFORMATION DANS "A" ET "B" N'EST PAS SUIVIE EXACTEMENT, UN FEU CAUSANT LA MORT OU DES DOMMAGES SÉRIEUX PEUT SE PRODUIRE.

Fig. 16-1 type coupleur rapide de fil de point culminant d'I

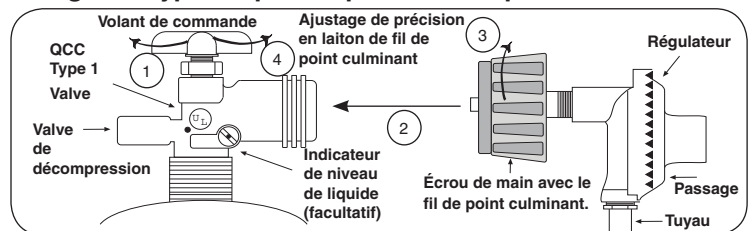

Pour la ventilation de propane, voir la section sur les exigences de boîtier.

SAFE USE & MAINTENANCE OF PROPANE GAS CYLINDERS

IMPORTANT FOR YOUR SAFETY

READ AND FOLLOW ALL WARNINGS PROVIDED WITH THE PROPANE-GAS CYLINDER.

When operating this appliance with a propane-gas cylinder, these instructions and warnings **MUST** be observed.

FAILURE TO DO SO MAY RESULT IN A SERIOUS FIRE OR EXPLOSION.

CYLINDER/CONNECTOR REQUIREMENTS

- a. Propane-gas cylinders, valves, and hoses must be maintained in good condition and must be replaced if there is visible damage to either the cylinder or valve. If the hose is cut or shows excessive abrasion or wear, it must be replaced before using the gas appliance (see e.).
- b. This unit, when used with a cylinder, should be connected to a standard 5-gallon (20 lb.) propane-gas cylinder equipped with an OPD (Overfill Prevention Device). The OPD has been required on all cylinders sold since October 1, 1998, to prevent overfilling.
- c. Cylinder dimensions should be approximately 12" (30.5 cm) in diameter and 18" (45.7 cm) high. Cylinders must be constructed and marked in accordance with the *Specifications for Propane Gas Cylinders of the U.S. Department of Transportation (D.O.T.)* or the National Standard of Canada, *CAN/CSA-B339, Cylinders, Spheres, and Tubes for Transportation of Dangerous Goods*.
- d. The cylinder used must include a collar to protect the cylinder valve, and the cylinder supply system must be arranged for vapor withdrawal.
- e. The pressure regulator and hose assembly used must match the specification for Type I by *ANSI Z 21.58/CGA 1.6* (see Fig. 17-1).
- f. The propane-gas cylinder valve must be equipped with a cylinder connection coupling device, described as Type I in the standard defined in paragraph e. above. This device is commonly described as an Acme thread quick coupler.
- g. If the propane-gas cylinder comes with a dust plug, place the dust cap on the cylinder valve outlet whenever the cylinder is not in use.

QUICK COUPLER OPERATION

To connect the regulator/hose assembly to the propane-gas cylinder valve fitting: Press the hand nut on the regulator over the Acme thread fitting on the cylinder valve. Turn the hand nut clockwise to engage the threads and tighten until snug.

The use of pliers or a wrench should not be necessary. Only cylinders marked "propane" may be used.

To disconnect: Turn the hand nut counterclockwise until detached (Fig. 17-1).

Important: Before using the unit, and after each time the cylinder is removed and reattached, check the hose for wear (see a.) and check all connections for leaks. Turn off the unit valves and open the main cylinder valve, then check connections with soapy water. Repair any leaks before lighting the unit.

CAUTION: Always turn the propane cylinder main valve off after each use, and before moving the unit and cylinder or disconnecting the coupling. This valve must remain closed and the cylinder disconnected while the appliance is not in use, even though the gas flow is stopped by a safety feature when the coupler is disconnected.

Carefully inspect the hose assembly each time before the gas is turned on. A cracked or frayed hose must be replaced immediately.

If the appliance is stored indoors, the cylinder must be disconnected and removed. Disconnected cylinders must be stored outdoors, out of the reach of children, with threaded valve plugs tightly installed, and must not be stored in a building, garage, or any other enclosed area.

FOR YOUR SAFETY

- a. DO NOT store a spare propane-gas cylinder under or near this appliance.
- b. NEVER fill the cylinder beyond 80-percent full.
- c. IF THE INFORMATION IN a. AND b. IS NOT FOLLOWED EXACTLY, A FIRE CAUSING DEATH OR SERIOUS INJURY MAY OCCUR.

Fig. 17-1 Type I Acme thread quick coupler

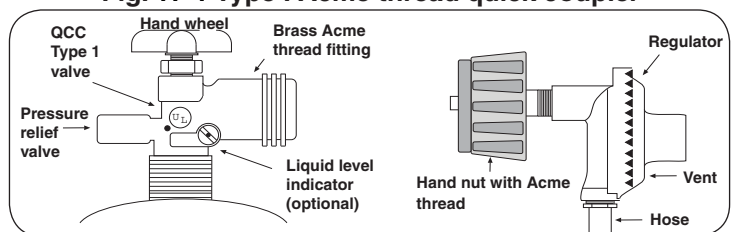

For propane ventilation requirements, see the ENCLOSURE REQUIREMENTS section.

COUNTER PREPARATION

Consult Table 1 for non-combustible enclosure cut-out dimensions. An RHP insulating liner must be used if any supporting construction is combustible. Consult the instructions that come with the liner for dimensions and additional installation information before beginning the installation.

This outdoor built-in grill must be supported by the stainless-steel hanger extending from the upper portion of the grill. The hanger rests on the left, right, and back of the countertop and on the two front structural supports with attached adjustable screws located below the control panel on the left and right sides.

The control panel is designed to sit flush against the enclosure front wall (see Fig. 18-2). If the non-combustible enclosure countertop extends beyond the front wall, creating a countertop overhang (see Fig. 18-1), it must be cut flush with the front wall for the width of the control panel or a gap will be created exposing the forward portions of the left and right side grill fire walls. Reference the MODEL SPECIFICATIONS section.

Note: It is not necessary to remove the control panel or knobs to install this unit.

CONNECT THE GAS SUPPLY

For propane cylinders:

For connecting a propane unit to a portable propane tank, read the safety warnings and follow the instructions in the section SAFE USE AND MAINTENANCE OF PROPANE GAS CYLINDERS.

Note: When a propane cylinder is installed inside of the enclosure, the guidelines found in the ENCLOSURE REQUIREMENTS section MUST be followed.

For household propane or natural gas units:

CAUTION: Use only C.S.A. listed stainless-steel flex connectors within the enclosure.

WARNING

A rubber or plastic connector will rupture or leak, resulting in an explosion or serious injury if used inside the appliance enclosure.

1. Run the attached flex connector routed under the left side of the grill to the gas stub.
2. **Turn OFF the gas supply at the source.**
3. A shut-off valve is required within 6 feet of the unit.

If shut-off valve is connected to end of gas supply stub:

- Connect the flex connector to the shut-off valve (see Fig. 18-3). Tighten securely.

If shut-off valve is installed in-line:

- Install the supplied flare adapter to the gas supply using a pipe joint compound resistant to all gasses (see Fig. 18-3). Tighten securely.
- Connect the flex connector to the flare adapter (see Fig. 18-3). Tighten securely.

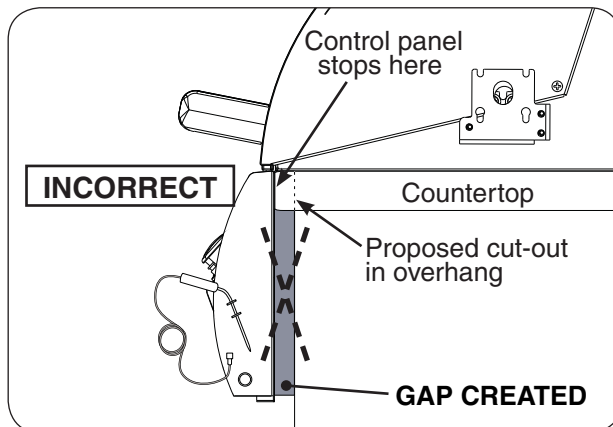

Fig. 18-1 Countertop overhang - incorrect cutout

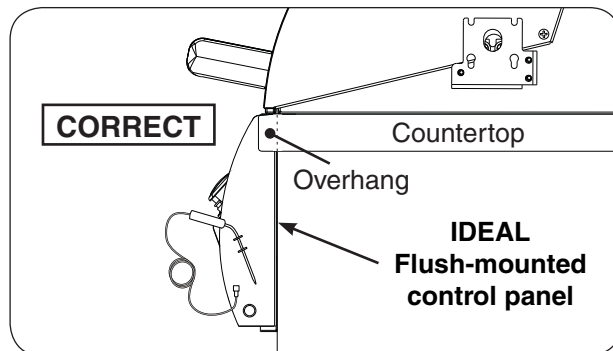

Fig. 18-2 Countertop overhang - correct cutout

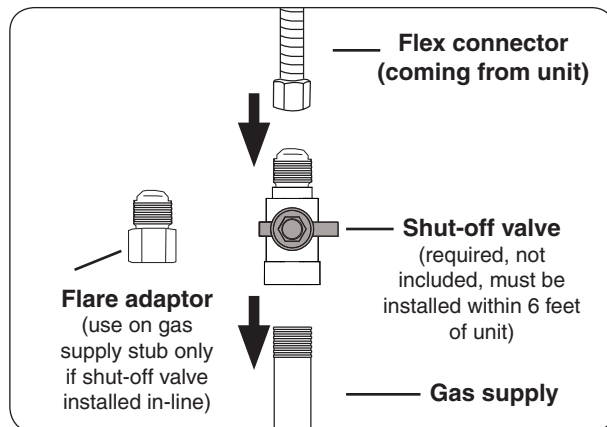

Fig. 18-3 Connecting to a gas line

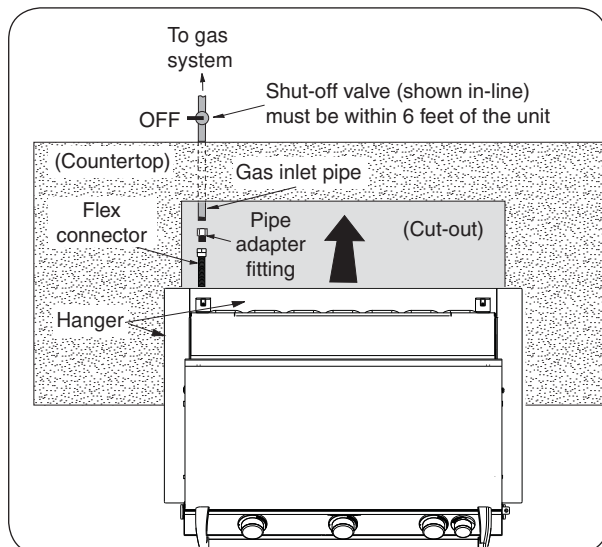

Fig. 18-4 Household propane & natural gas diagram

INSTALLATION (cont.)

- Turn all burner control knobs to the **OFF** position. Turn the gas supply on. Then carefully check all gas connections for leaks with a brush and half-soap/half-water solution before lighting. **NEVER USE A MATCH OR OPEN FLAME TO TEST FOR LEAKS.**
- Close the shut-off valve, then slide the grill into place. Do not to pinch, kink, or damage the gas connector line.
- Rotate the adjustable support screws to the left to raise and to the right to lower the respective side of the appliance grill. Use a $\frac{7}{16}$ " open-end wrench as needed. See Fig. 19-1.

Important: Do not extend the support screws so far that any part of the hanger is raised off the counter top.

INSTALL ZONE DIVIDERS

Place the zone dividers as shown (Fig. 19-2) into the grooves in the inner firewall of the grill to allow for maximum heat control and thermometer accuracy in each zone. Remove and store during rotisserie use.

INSTALL THE FLAVOR GRIDS

Place the flavor grids directly onto the studs on the burners. See Fig. 19-3. **The slightly larger grids are designed to be placed over the outside burners, and the slightly smaller grid(s) over the inner burner(s).** The flavor grids allow heat from the burners to be evenly distributed throughout the cooking area.

INSTALL THE COOKING GRIDS

Using the grid/smoker lid lifter, place each cooking grid onto the front and rear grid rests of the grill. See Fig. 19-4.

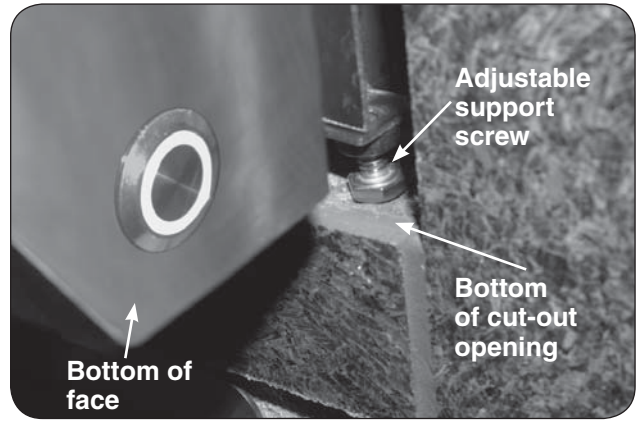

Fig. 19-1 Adjust support screws

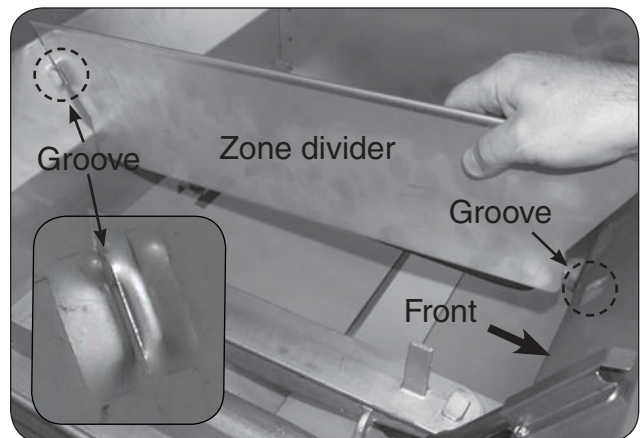

Fig. 19-2 Install zone dividers

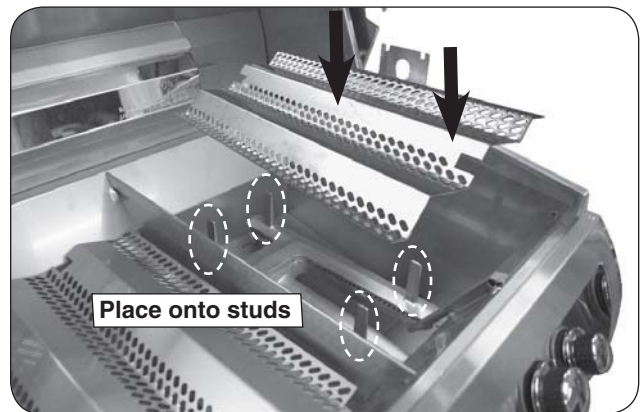

Fig. 19-3 Install flavor grids

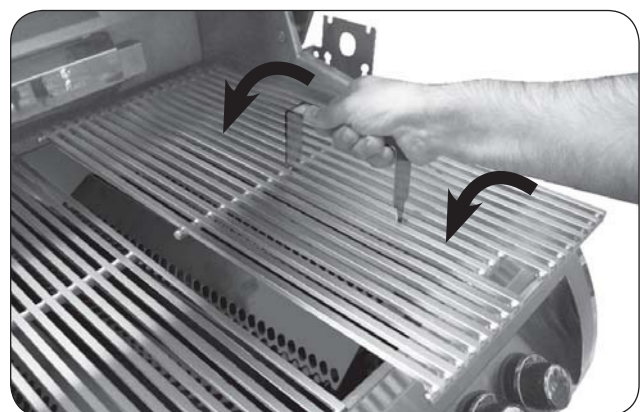

Fig. 19-4 Install cooking grids

INSTALL THE DRIP TRAY

Your grill includes a pack of four drip tray liners. Place a liner into the drip tray as shown in Fig. 20-1, and fully insert the drip tray into the bottom front of the control panel.

Note: The liner must fit under the rear lip and two front tabs found on the drip tray.

INSTALL THE WARMING RACK

The warming rack (Fig. 20-2) is packed separately. To install the warming rack, carefully insert the rack hangers into the two holes in the back of the inner oven hood, then lower the front of the rack to a level position.

Note: Removing the warming rack before using the rotisserie will leave more clearance for the meat being cooked (if applicable).

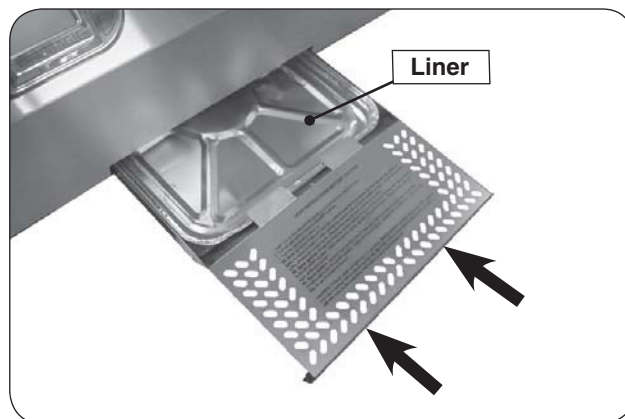

Fig. 20-1 Install drip tray

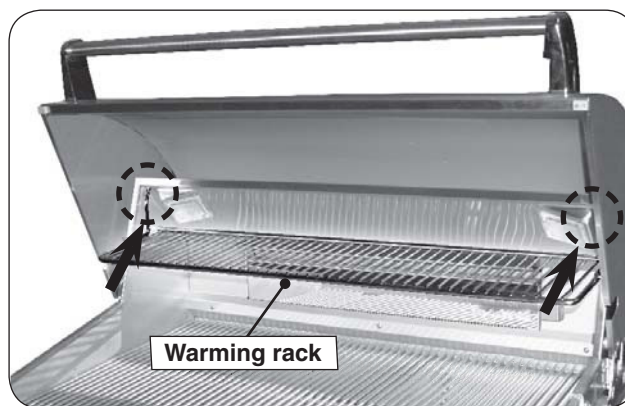

Fig. 20-2 Install warming rack

ELECTRICAL INSTALLATION

POWER SUPPLY HOOKUP

CAUTION: IMPROPERLY CONNECTED WIRES WILL CAUSE DAMAGE TO THE GRILL AND MAY RESULT IN PROPERTY DAMAGE AND/OR PERSONAL INJURY.

This grill includes a power supply box. When installing the power supply box:

- It **MUST** be located at least 12 inches below the bottom of the grill (see Fig. 21-3).
- The wire extension that exits from the control panel **MUST** be routed directly downward. This will prevent overheating. **DO NOT** route the wire extension below the grill (see Fig. 21-3).

Note: For enclosures with a solid area beneath the grill, a cutout must be made near the wire extension to allow for the above requirement. If an insulating liner is installed, route the wire down through the nearest hole possible.

- **DO NOT** block the vent holes found on the box.

Fasten the power supply box to the inside of the enclosure using appropriate hardware for your enclosure.

The electrical connections from the power supply box to the grill electrical systems come pre-connected.

WARNING: Electrical Grounding Instructions - This appliance is equipped with a three-pronged (grounding) plug for your protection against shock hazard and should be plugged directly into a properly grounded three-prong receptacle. Do not cut or remove the grounding prong from this plug.

CONNECT THE POWER SUPPLY TO LINE POWER

Connect the cord coming from the unit's power supply to a **120VAC (15 AMP minimum) GFCI GROUNDED 3-wire receptacle**. The GFCI receptacle must be a WEATHER-PROOF IN-USE COVERED RECEPTACLE.

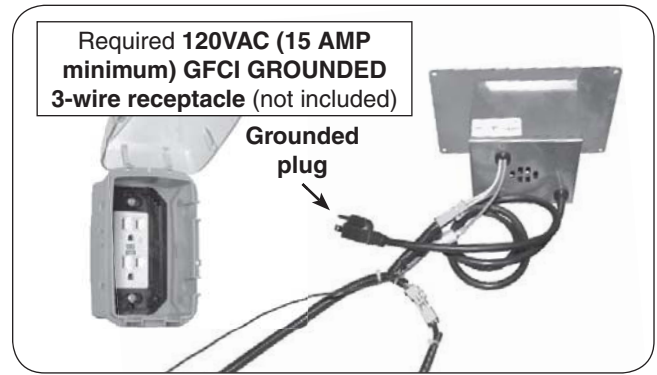

Fig. 21-1 Power supply detail

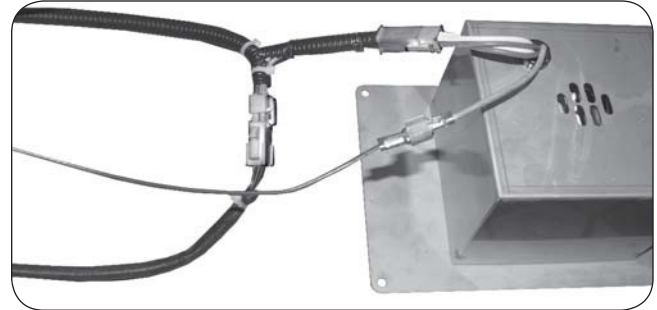

Fig. 21-2 Wire connections

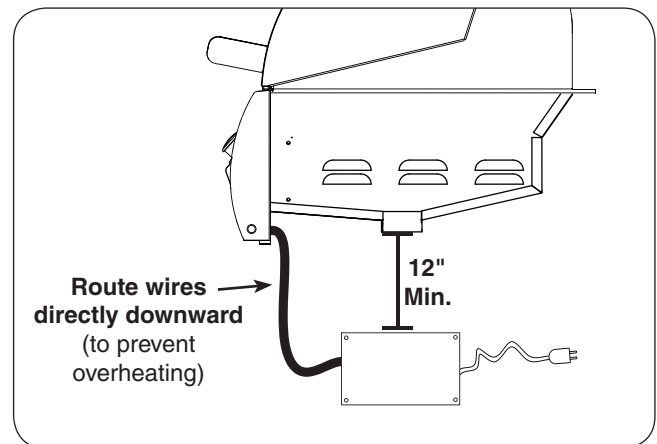

Fig. 21-3 Power supply clearance

IDENTIFICATION OF GRILL CONTROLS

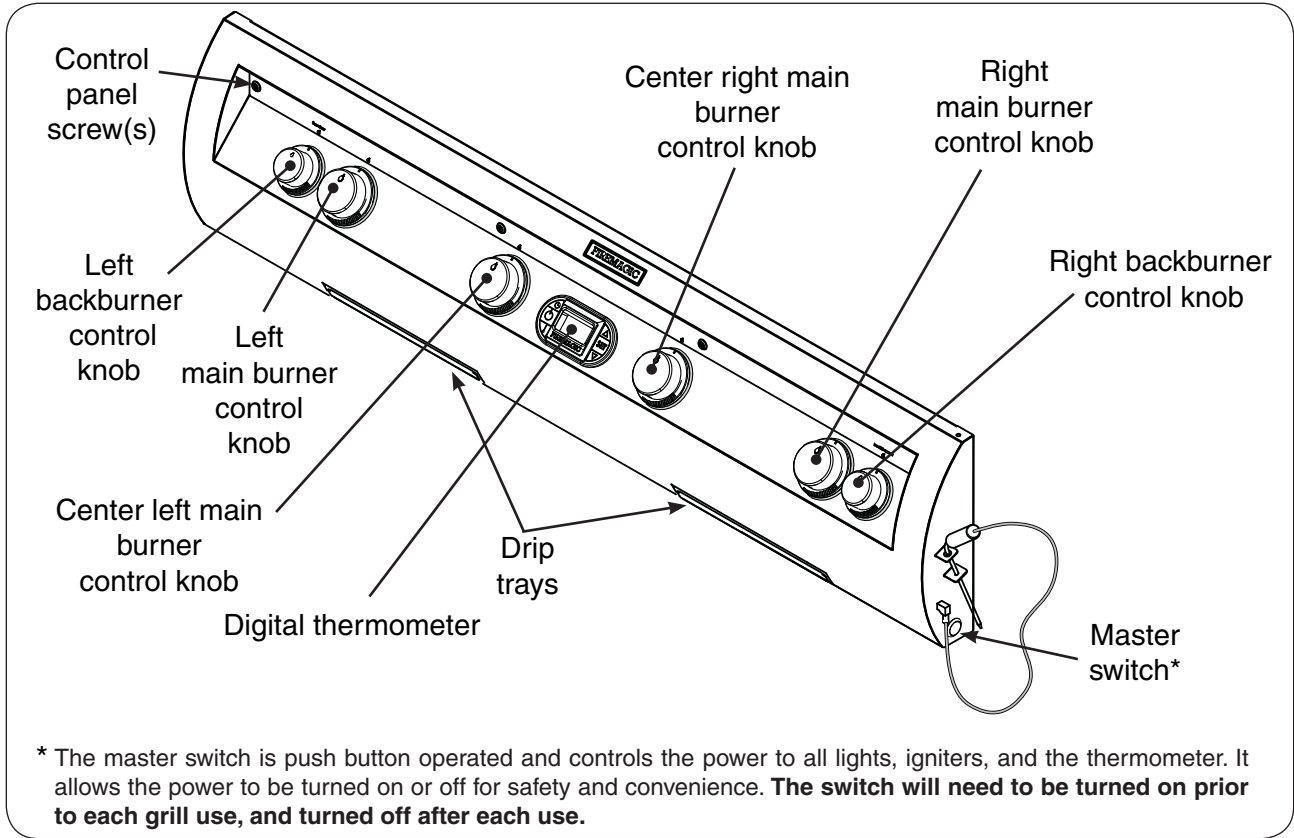

Fig. 22-1 E1060i controls

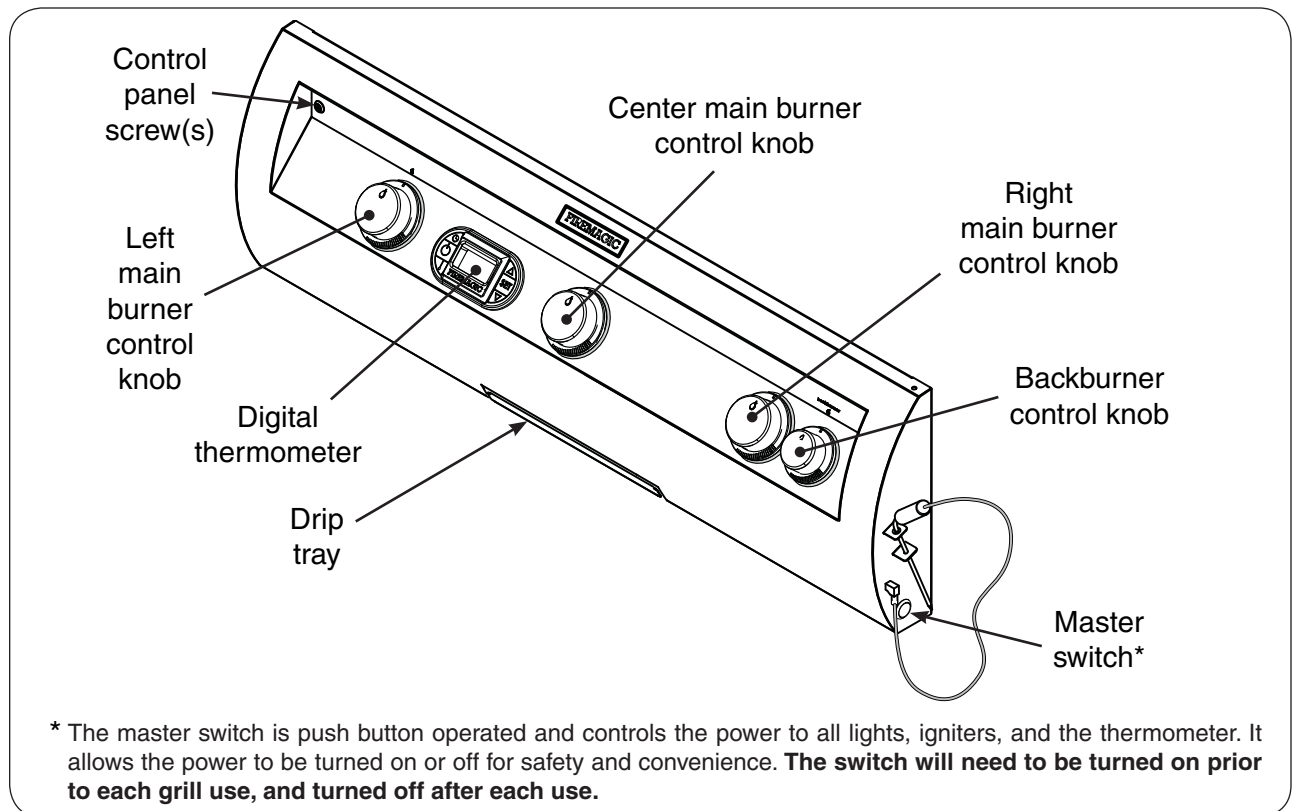

Fig. 22-2 E660i and E790i controls

LIGHTING (IGNITION) INSTRUCTIONS

Read all instructions before lighting, and follow these instructions each time you light the unit.

ELECTRONIC LIGHTING

Note: This unit must be connected to 120VAC power for electronic lighting.

1. Open lid(s) or remove cover(s) from burner(s) to be lit.
2. Turn all gas control knob(s) to their **OFF** position(s).
3. Turn on the gas at its source and press the master switch.

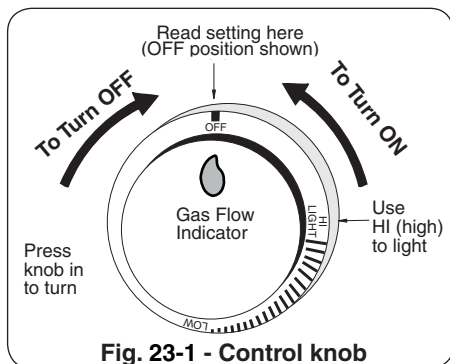

Fig. 23-1 - Control knob

Note: DO NOT turn on more than one valve at a time for either electronic or manual lighting.

4. Depress the desired control knob **for 5 seconds**, then, while pressing turn it counterclockwise to the **HI LIGHT** position. Once the burner lights, release the knob.

CAUTION: If a burner does not light within five (5) *seconds* of turning on the control knob, depress the knob and turn it to the **OFF** position. **WAIT FIVE (5) MINUTES** before repeating step 4. If you smell gas, follow the instructions on the cover of this manual. If the burners still do not light after several attempts, refer to the instructions for manual lighting.

5. Repeat step 4 for each additional burner to be lit.

WHEN USING A PORTABLE PROPANE TANK

Propane tanks are equipped with a safety shutdown device that may cause low or no gas pressure/flame at the burners if operating and lighting instructions are not followed exactly (See important note in the TROUBLESHOOTING section for more details.)

MANUAL LIGHTING

CAUTION: Always wait five (5) minutes for gas to clear after any unsuccessful lighting attempt.

1. Follow steps 1 through 3 (left).
2. Insert either a burning long-barrel butane lighter or a burning long-stem match through the cooking grid opening to the top of the lighting tube (Fig. 23-2). For backburners, hold the flame against the surface of the backburner.
3. Hold the match / lighter flame at the top of the lighting tube **for 5 seconds**, or, next to the backburner. Then depress the appropriate control knob and while pressing turn it counterclockwise to the **HI LIGHT** position. Remove the lighter or match when the burner lights, and release the control knob.
4. If the burner does not light within five (5) seconds of turning the control knob, **immediately depress the knob and turn the valve to OFF**. **WAIT FIVE (5) MINUTES** before repeating steps 2 through 4 of the MANUAL LIGHTING instructions.

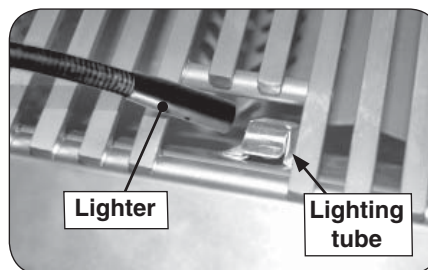

Fig. 23-2 - Manual lighting

SHUTTING OFF THE UNIT

To shut off the unit, depress each valve control knob and while pressing turn it clockwise to the **OFF** position.

Always close the valve from the gas supply after each use of the unit.

For your convenience and safety; when the control knob is in the on position, the gas flow indicator will change from blue to red. (Red indicates gas flow.) See Fig. 23-1.

ALLUMAGE DES INSTRUCTIONS (D'ALLUMAGE)

Lisez toutes les instructions avant l'allumage, et suivez ces instructions chaque fois vous lumière le unité.

ÉCLAIRAGE ÉLECTRONIQUE

Note: Le unité doit être relié à la puissance 120VAC pour l'éclairage électronique.

1. Ouvrez les couvercles ou enlevez les couvertures des brûleurs pour être Lit.
2. Tournez tous les boutons de commande de gaz à leurs positions de repos.
3. Allumez le gaz à sa source et appuyez sur l'interrupteur principal.

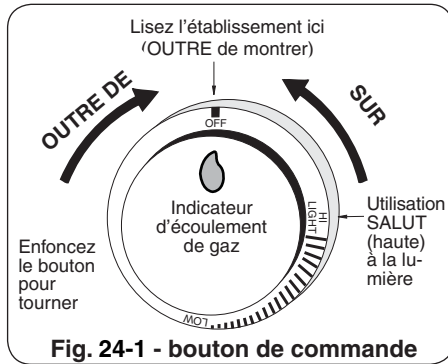

Fig. 24-1 - bouton de commande

4. Diminuez le bouton de commande désiré pendant 5 secondes, puis, et tout en pressant le tour il dans le sens contraire des aiguilles d'une montre dans la position LÉGÈRE de HI. Une fois que le brûleur s'allume, libérez le bouton.

ATTENTION : Si un brûleur ne s'allume pas dans cinq (5) secondes d'allumer le bouton de commande, enfoncez le bouton et tournez-le à la position de repos. ATTENDEZ CINQ (5) MINUTES avant de répéter l'étape 4. Si vous sentez le gaz, suivez les instructions sur la couverture de ce manuel. Si les brûleurs ne s'allument toujours pas après que plusieurs tentatives, se rapportent aux instructions pour l'éclairage manuel.

5. Répétez l'étape 4 pour que chaque brûleur additionnel soit Lit.

ÉCLAIRAGE MANUEL

ATTENTION: Attendez toujours cinq (5) minutes le gaz pour se dégager après que n'importe quelle tentative non réussie d'éclairage.

1. Suivez les étapes 1 à 3 (à gauche).
2. Passez un allumeur brûlant de butane de long-baril ou une allumette brûlante de long-tige dans la grille à cuire s'ouvrant au dessus du tube d'éclairage. (Fig. 24-2). Pour des backburners, tenez la flamme contre le surface du backburner.
3. Maintenez le match / flamme d'un briquet à la partie supérieure du tube d'éclairage pendant 5 secondes, ou, à côté de la veilleuse. Puis appuyer sur le bouton de contrôle approprié et en appuyant tourner dans le sens antihoraire à la position HI LIGHT. Retirez le briquet ou des allumettes quand le brûleur s'allume, puis relâchez le bouton de commande.
4. Si le brûleur ne se allume pas dans les cinq (5) secondes de tourner le bouton de commande, enfoncez immédiatement le bouton et tournez la valve à AU LOIN. ATTENDEZ CINQ (5) MINUTES avant de répéter les étapes 2 à 4 des instructions manuelles d'éclairage.

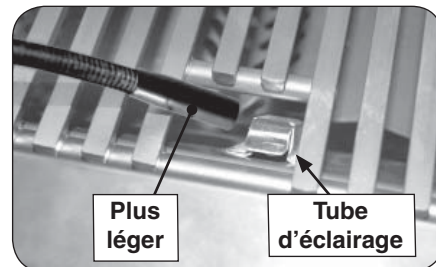

Fig. 24-2 - Éclairage manuel

ARRÊT DU UNITÉ

Pour couper le unité, diminuez chaque bouton de commande de valve et tout en pressant tour il dans le sens des aiguilles d'une montre à la position de repos.

Fermez toujours la valve de la fourniture de gaz après chaque utilisation du unité.

EN EMPLOYANT UN RÉSERVOIR DE PROPANE PORTATIF

Des réservoirs de propane sont équipés d'un dispositif d'arrêt de sûreté qui peut ne pas causer le bas ou aucunes pression de gaz/flamme aux brûleurs si le fonctionnement et l'allumage des instructions ne sont pas suivis exactement (voir la note importante dans la section de dépannage pour plus de détails.)

Pour votre convenance et sûreté ; quand le bouton de commande est dans la position de fonctionnement, l'indicateur d'écoulement de gaz changera de bleu en le rouge. (Le rouge indique l'écoulement de gaz.) Voir la Fig. 24-1.

DIGITAL THERMOMETER / INTERIOR AND KNOB LIGHTS

Your grill comes with a digital thermometer for temperature monitoring and timed cooking. Pressing **any** button will turn on the thermometer. The thermometer will automatically shut off after 5 minutes if no temperature change is detected.

Note: The thermometer also controls the interior lights, and knob backlights. Thermometer shutdown will not shut off these lights; they must be manually shut off.

The thermometer is located on the control panel between the control knobs.

Plug in the meat probe on the right side of the control panel as shown in Fig. 25-1.

For best performance and temperature readings center the zone separators properly between each burner (see PARTS LIST and INSTALLATION - INSTALL ZONE DIVIDERS section).

Read the following sections completely regarding thermometer operation. Refer to Fig. 25-2 for thermometer orientation and button locations.

Whenever the master switch is turned off or the power supply is disconnected, allow 30 seconds for the thermometer to initialize the next time it is powered on.

Default Screen

Press any button to turn the thermometer ON. The default screen will be displayed. All temperatures for the cooking zones (see GRILLING TIPS section) and the meat probe will be shown (Fig. 25-3).

Menu Screen

Press any button to turn the thermometer ON. The default screen will be displayed. Press the **MENU** button to display its screen. Press the up/down arrow to scroll through the options. See Fig. 25-4.

Note: The menu screen will return to the default screen after approximately 30 seconds of no activity. Press the **MENU** button to manually return to the default screen.

Interior and Knob Lights

1. Press the light button to turn both the interior lights and knob backlights ON (see Fig. 25-2). The interior lights will temporarily shut off when the hood is closed (except for Magic View models).
2. Press the light button once to turn the interior lights OFF, and a second time to turn the knob backlights OFF.

Note: Thermometer shutdown will not shut off these lights; they must be manually shut off by turning the thermometer back ON and pressing the light button.

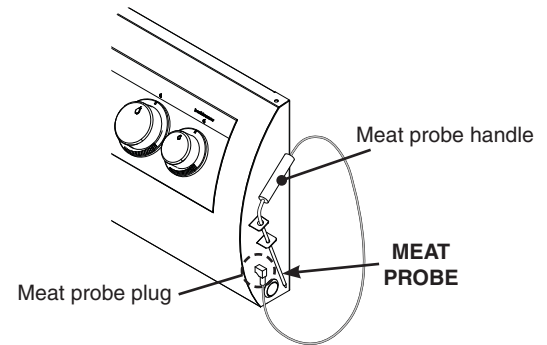

Fig. 25-1 Meat probe detail

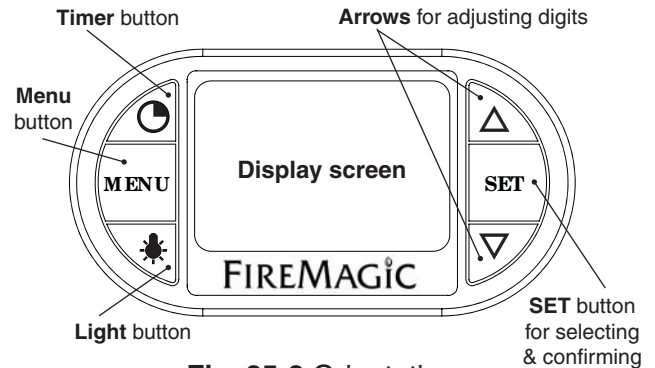

Fig. 25-2 Orientation

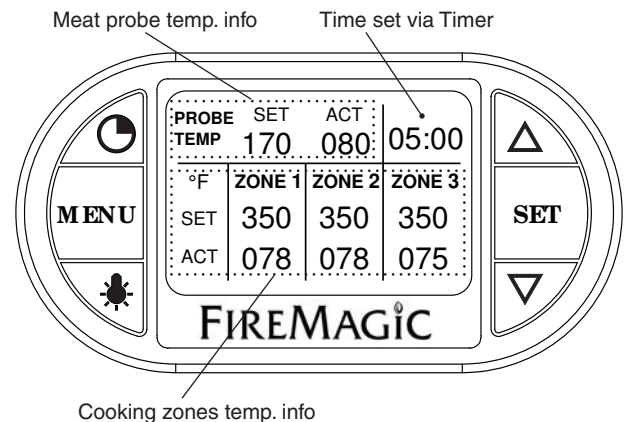

Fig. 25-3 Default screen detail



Fig. 25-4 Menu screen

Setting a Zone and/or Meat Probe Temperature

1. From default screen, press the down arrow to the desired zone / meat probe area (flashing). Press **SET**.
2. The selected location's temperature screen will be displayed. Use the arrows to set the desired temp. The actual temp. will also be shown. See Fig. 26-1.

Note: **PRESSING** the arrows will adjust the desired temp. by increments of one degree. **HOLDING** them down (for several seconds) will adjust the temp. rapidly.

3. Press **SET** to return to the default screen. Repeat as necessary for all other areas.

The display will flash red and the alarm will sound (if set to do so) when an area's temperature reaches its set temperature. Press any button to silence.

Grill Guide and Meat Probe

The grill guide displays recommended ready temperatures for various meats (See Fig. 26-2).

1. Under the menu screen select GRILL GUIDE. Press **SET**.
2. Press the up/down arrow to view the desired meat.
3. Note the temp. and press **SET**. This will take you to the meat probe temperature screen.
4. Use the arrows to set the noted temp.
5. Press **SET** to return to the default screen.

Inserting the meat probe into the cooking meat will give an actual temp. reading. The display will flash red and the alarm will sound (if set to do so) when the actual temp. reaches the set temp. Press any button to silence.

Do not leave the meat probe in the meat for a prolonged period of time, or with the hood closed. The probe is calibrated specifically for use at temperatures between 130°F and 180°F.

Setting the Timer

1. Press the timer button. Use the arrows to set the desired amount of time (see Fig. 26-4.)
2. Press **SET** to return to the default screen.

The time remaining will be shown on the default screen. Once the time reaches zero; the display will flash red and the alarm will sound. Press any button to silence.

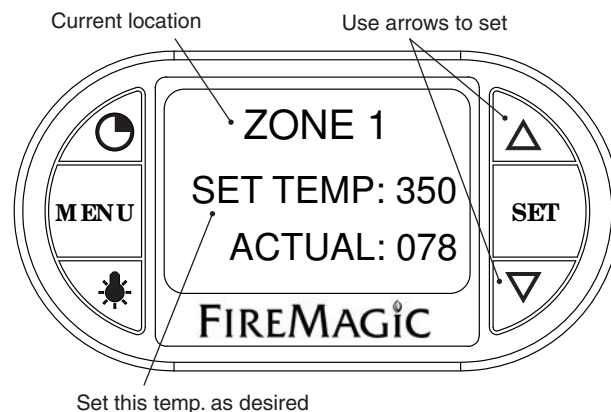

Fig. 26-1 Area temp. screen (zone 1 shown)

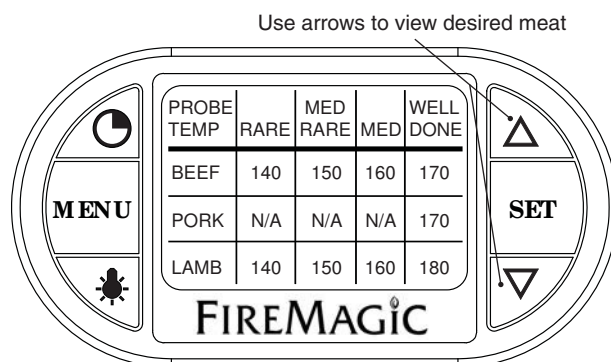

Fig. 26-2 Grill Guide screen

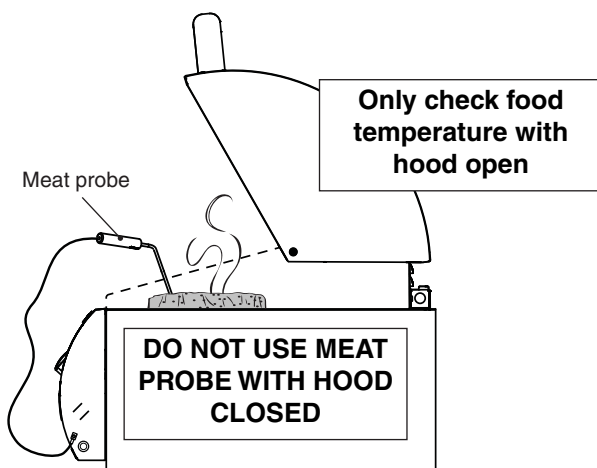

Fig. 26-3 Meat probe

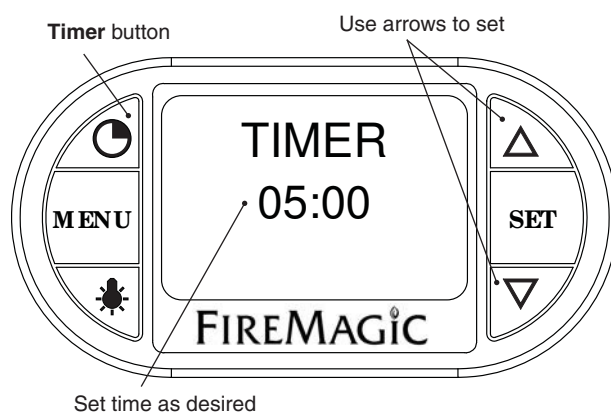

Fig. 26-4 Timer screen

Setting the Alarm (Zones or Meat Probe)

The alarm can be individually set (ON or OFF) for the meat probe and each cooking zone. The default setting has the alarm OFF for the meat probe and cooking zones. The alarm always sounds for the TIMER.

1. Under the menu screen select ALARM. Press **SET**.
2. Use the up/down arrow to select the desired alarm, and press the light button to turn the alarm ON/OFF.
3. Press **SET** to return to the menu screen.
4. Press **MENU** to return to default screen.

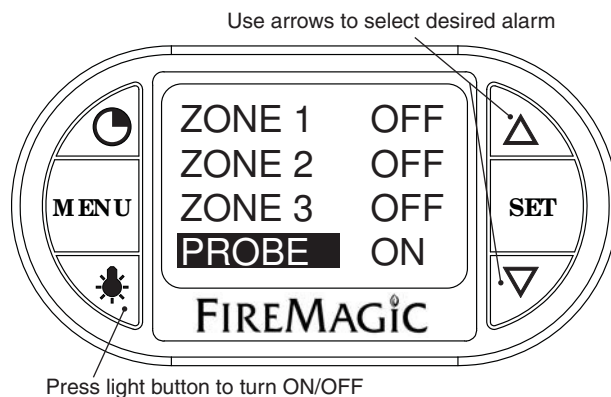

Fig. 27-1 Alarm screen

Setting the Thermometer Backlight

The default color for the thermometer backlight is blue. The color may be changed as desired by turning the three base colors ON/OFF. Various combinations will result in different colors.

1. Under the menu screen select BACKLIGHT. Press **SET**.
2. Use the up/down arrow to select the desired color, and press the light button to turn the color ON/OFF.
3. Press **SET** to return to the menu screen. The new color will now show.
4. Press **MENU** to return to default screen.

Note: Turning all colors OFF will result in no backlight.

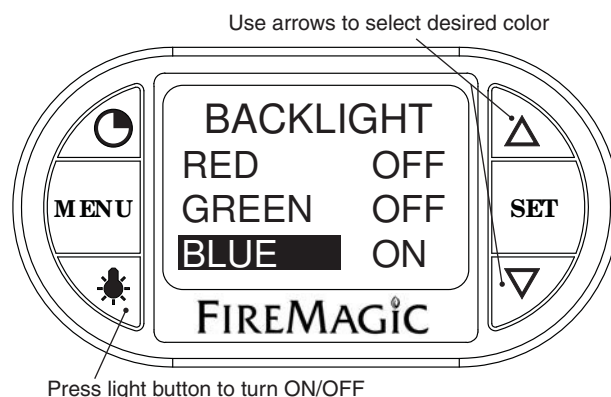

Fig. 27-2 Backlight screen

Changing Temperature Scale (°C/°F)

1. Under the menu screen select SETUP. Press **SET**.
2. Press **SET** to select SETUP F C.
3. Select as desired and press **SET** to return to the menu screen.
4. Press **MENU** to return to default screen.

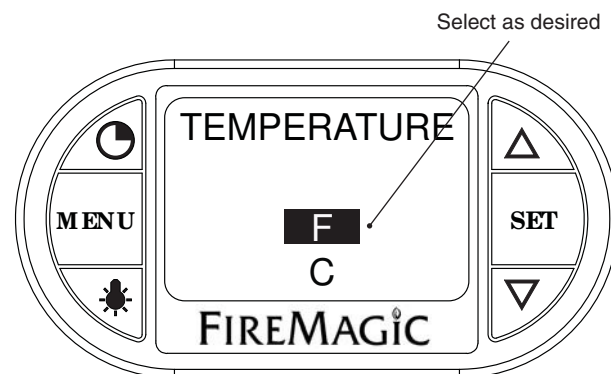

Fig. 27-3 Temperature scale screen

ROTISSERIE INSTRUCTIONS

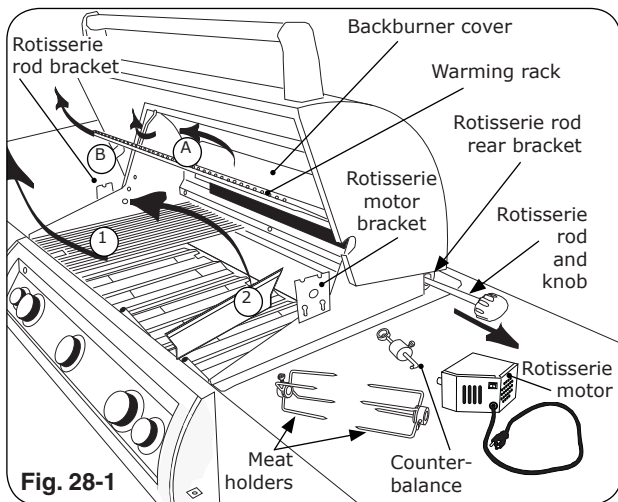

Fig. 28-1

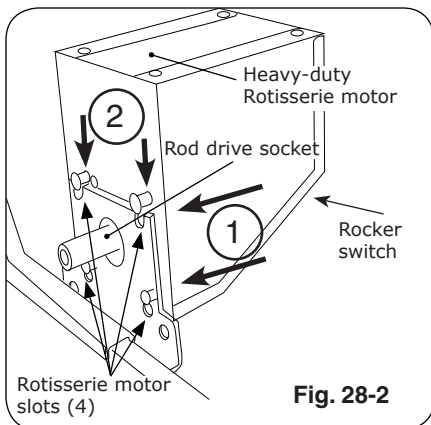

Fig. 28-2

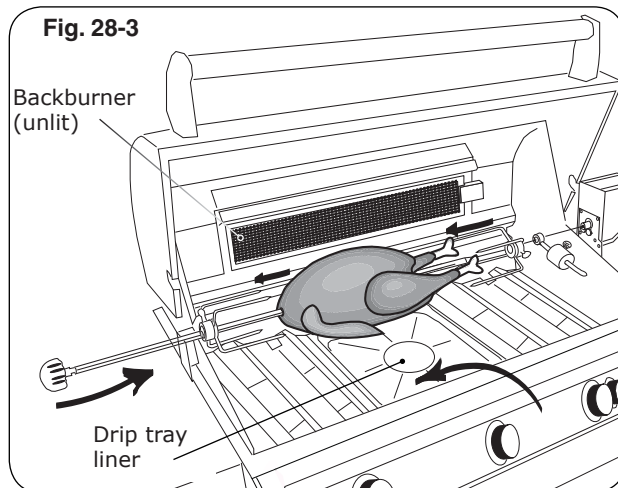

Fig. 28-3

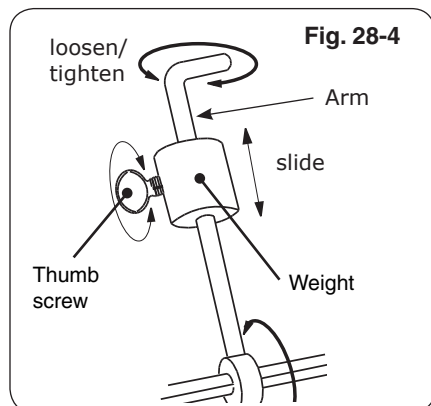

Fig. 28-4

CAUTION: WHEN USING THE BACKBURNER; KEEP THE OVEN LID CLOSED TO PREVENT HEAT LOSS, PROVIDE PROPER CONVECTION, AND PROVIDE PROPER VENTING. THIS WILL ENSURE EVEN COOKING TEMPERATURES.

DO NOT KEEP YOUR OVEN LID OPEN DURING ROTISSING, AS THIS MAY CAUSE PERSONAL INJURY, OR IN SOME CASES, IN WINDY CONDITIONS, DAMAGE TO THE GRILL.

DO NOT USE THE ROTISSERIE MOTOR IN THE RAIN. DO NOT LEAVE THE MOTOR ON THE GRILL WHEN NOT IN USE.

1. Remove warming rack, backburner cover, cooking grids, and zone separators. Leave the flavor grids on if possible.
2. Slide rotisserie motor fully onto motor bracket (right side, Fig. 28-1 and 28-2).
3. Remove rotisserie rod from rear bracket (Fig. 28-1) and attach knob if necessary.
4. Slide the left meat holder onto the rod (and tighten), the meat onto the rod and into the holder, followed by the right meat holder onto the rod and into the meat as shown in Fig. 28-3. Tighten the right meat holder. Be sure the meat is centered and balanced as well as possible.
5. Hold both ends of the rod so it settles freely (do not grip tightly). Allow the rod to rotate until the heavy side of the meat rests downward.
6. The counterbalance may then be attached to even weight distribution. Slide counterbalance onto rod next to the meat holder. Loosen the arm and point it upward opposite the heavy side of the meat. Tighten the arm.
7. Slide the counterbalance weight up or down the arm until the rod rotates most evenly then tighten thumb screw (Fig. 28-4 and Fig. 28-5).
8. Insert the pointed end of the rod into the motor drive socket and the groove next to the knob into the left support bracket.
9. To keep drippings off the burners and simplify cleanup, place Fire Magic® drip tray liners under the meat, if desired (Fig. 28-3).
10. Plug-in the rotisserie motor and press the rocker switch to start (Fig. 28-2).
11. Light backburner per lighting instructions in this manual (or on drip tray handle) and close oven lid.

Important: Turn the backburner to low or off when stopping the rotisserie to prevent overcooking.

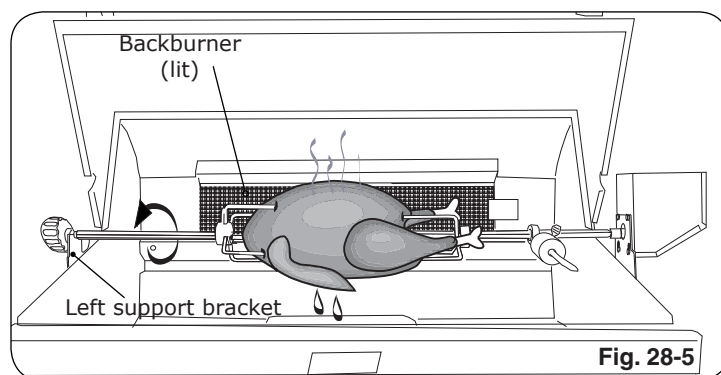
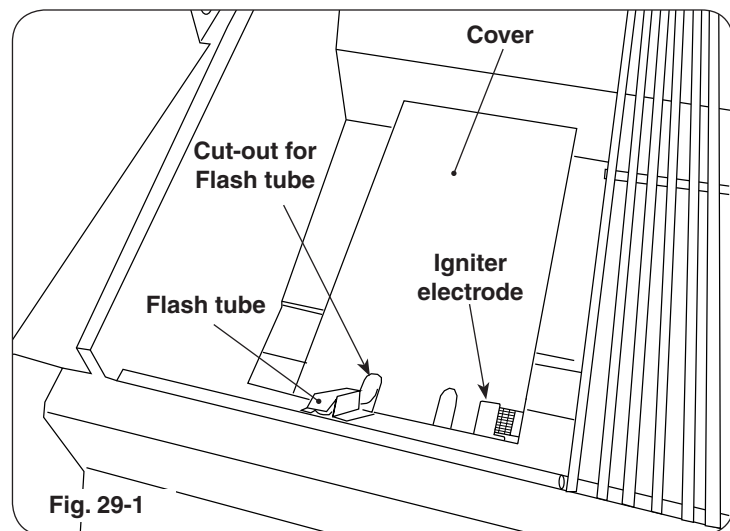

Fig. 28-5

OPTIONAL INFRARED BURNER OPERATION

The infrared (IR) searing burner (optional) cooks with a powerful radiant heat.



Light the infrared burner following the LIGHTING INSTRUCTIONS in this manual or printed on the drip tray. Follow these guidelines when operating the Infrared burner:

- **DO NOT** place food on the cooking grid until the IR burner glows orange (Fig. 29-3). Drippings are heated and evaporate instead of sticking to and impairing burner function.
- For cleaning purposes; always leave your burner on (after cooking) for an additional 5 minutes, to allow for a burnoff period. This is important to keep your burner clean and operating properly. **As the burner is self cleaning (at full temperature); avoid the use of cleaners or abrasives.**
- When not in use, **always** cover the infrared burner with the stainless-steel cover. This protects the burner from drippings (from other cooking), airborne particles, and foreign objects (Fig. 29-2).
- Do not strike or scratch the burner ceramic as it may chip, crack, or break (Fig. 29-2).

Note: Digital thermometer does not give accurate readings for zones using infrared burners.

Important: When grilling with the infrared burner, always place a cooking grid above it. The cooking grid must be removed for rotisserie cooking.

CAUTION: DO NOT operate your IR burner with the oven hood closed.

CAUTION: Never attempt to operate the IR burner with the protective cover in place.

WARNING

Only handle the infrared burner cover when the unit is cold or with a well-insulated long-handled tool or heat resistant gloves.

SIDE VIEW (with cover on)

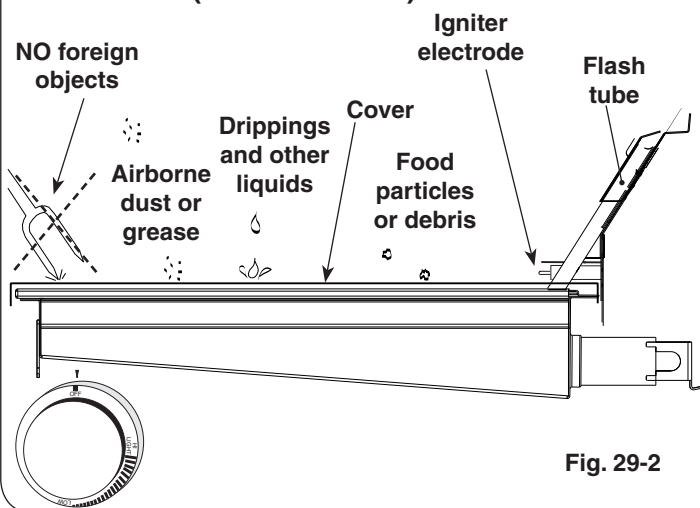

Burner ceramic must be protected with cover when burner is not in use.

SIDE VIEW (burner on HI LIGHT and glowing orange)

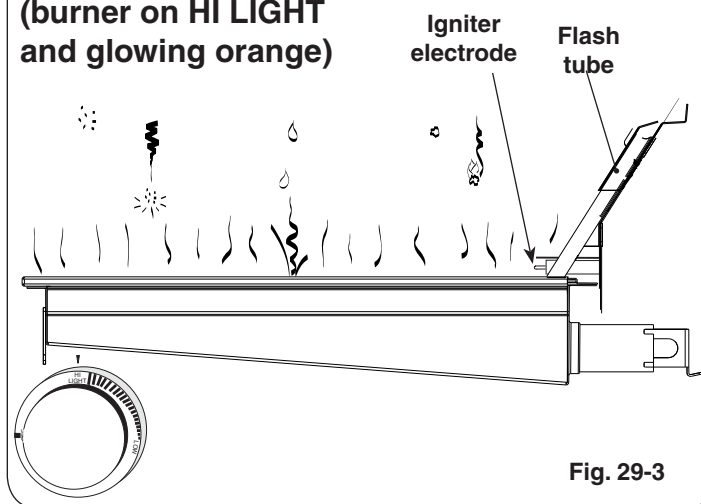

Drips and particles evaporate before hitting infrared burner when cooking at the maximum setting.

Note: Flavor grids are not to be used with infrared burners.

To ensure proper operation, all infrared burners (back and main) must be operated on the HI setting for a minimum of 10 minutes. Thereafter, the flame may be lowered as desired.

CAUTION: Always monitor the infrared burner flame when operated on low, as it may blow out in high-wind conditions.

CHARCOAL/SMOKER BASKET (IF EQUIPPED)

CAUTION: Ensure the grill is completely cool and the knobs are in the OFF position.

Note: This basket is designed for use over main burners only. DO NOT USE OVER INFRARED BURNERS.

BASKET INSTALLATION

1. Place the metal grid inside the basket frame (see Fig. 30-2).
2. Remove the cooking grid and flavor grid from the main burner where you wish to set the basket.

Note: Use the grid/smoker lid lifter (included) to remove the cooking grid.

3. Place the basket onto the burner in place of the flavor grid. Align the basket cutouts over the burner supports (see Fig. 30-3 and Fig. 30-4).

If using the basket for charcoal cooking, proceed to the next section. If using the basket for smoking, skip to the SMOKING section.

Note: Some distortion to the metal grid may occur during cooling (after use). This is normal and will not affect the efficiency of the basket during use.

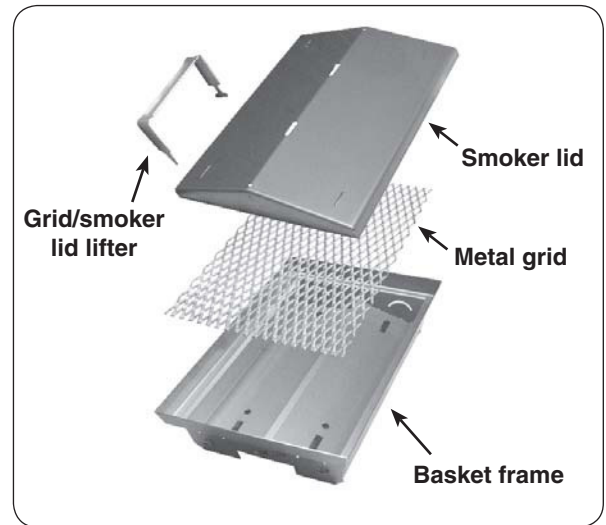

Fig. 30-1 Charcoal/smoker basket items

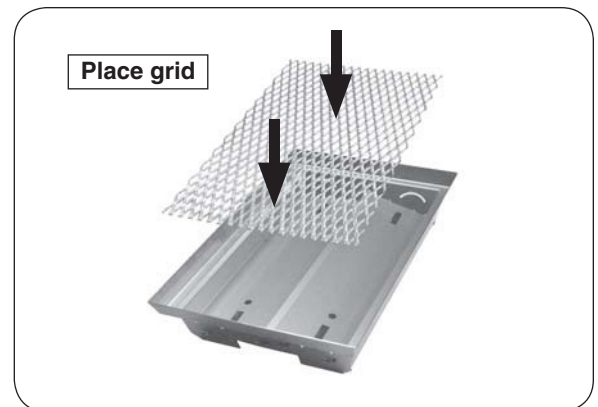

Fig. 30-2 Place metal grid inside basket

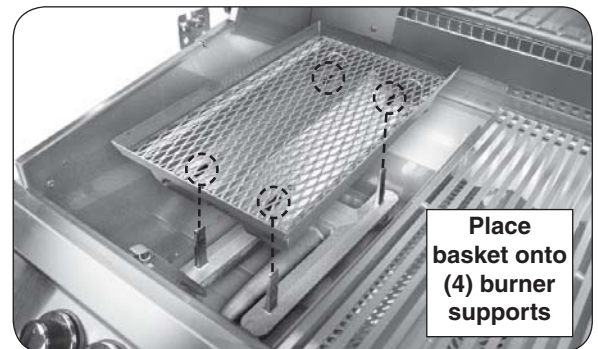

Fig. 30-3 Place basket onto burner

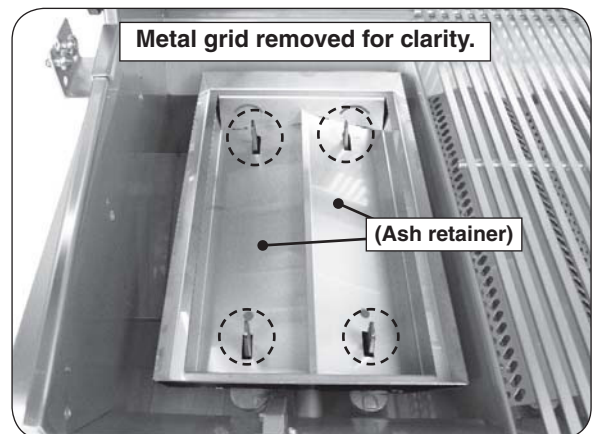

Fig. 30-4 Basket placement detail

CHARCOAL COOKING

1. Load charcoal onto the metal grid (see Fig. 31-1).

Important: When loading the charcoal, a $\frac{3}{4}$ " clearance below the cooking grid must be maintained.

WARNING: The basket is designed and engineered to be used with plain charcoal. **DO NOT** use quick-light charcoal as it is unnecessary and could be dangerous.

Important: DO NOT use the smoker lid when cooking with charcoal.

2. Replace the cooking grid back onto the grill.

Note: Do not re-install the flavor grid.

3. Ignite the burner under the basket. Keep the burner on the **HI** setting until the charcoal remains lit without application of flame from the burners (7-10 minutes).

Note: Keep the oven hood open until ready to cook.

4. Once the charcoal is generating even heat and is ready for cooking, shut off the burner and use the oven hood as normal.

Note: The digital thermometer (if equipped with your grill) does not give accurate readings for that designated zone that is cooking with charcoal.

5. After use (when the unit has cooled down and the coals are completely extinguished), remove the basket from the grill and empty the ash from the ash retainer into a fireproof container. Clean off burners and igniters as needed.

Important: Observe all safety information in your grill owner's manual and all warnings supplied with your charcoal.

SMOKING

1. Place wood chips/chunks (flat and evenly) onto the metal grid (see Fig. 31-2). Wood pre-soaked for at least 12 hours is recommended.

Important: Do not pile chips/chunks higher than the basket walls.

2. Using the grid/lid lifter, install the smoker lid (see Fig. 31-3).

3. Replace the cooking grid back onto the grill.

Note: Do not re-install flavor grid.

4. Ignite the burner under the basket. Keep the burner on the **HI** setting for about 10 minutes or until a steady amount of smoke is rising from the smoke vents. Then turn to **LOW** setting.

Note: A full basket can produce smoke for up to two hours.

Note: The digital thermometer (if equipped with your grill) does not give accurate readings for that designated zone being used for smoking.

5. After use (when the unit has cooled down and the wood chips/chunks are completely extinguished), remove the basket from the grill and remove the remaining wood pieces from the grid and empty the ash from the ash retainer into a fireproof container. Clean off the burners and igniters as needed.

Important: Observe all safety information in your grill owner's manual and all warnings supplied with your wood chips/chunks.



Fig. 31-1 Load charcoal into basket



Fig. 31-2 Load wood chips/chunks



Fig. 31-3 Install smoker lid

COOKING ZONES

Your grill is divided into three cooking zones, each corresponding to a burner. Burners are numbered starting at one (1) on the left, going to three (3) on the right (see Fig. 32-1). The cooking zones are monitored by the digital thermometer.

Note: E1060 models contain an additional cooking zone, on the far left of the grill. This zone is not monitored by the digital thermometer.

Each cooking zone is designed to be controlled individually by the burner control knob.

WIND CONSIDERATIONS

Wind direction can have an effect on the grill, especially with the oven open. For maximum stability and convenience, position the grill so that the oven opens toward any prevailing wind (Fig. 32-1).

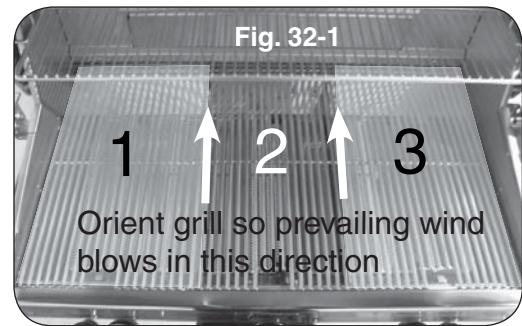

CARE & CLEANING

APPLIANCE MUST BE COMPLETELY COOL WHEN CLEANING. DO NOT SPRAY ANY CLEANER OR LIQUIDS ON THE APPLIANCE WHEN HOT.

The appliance *must* be cleaned as often as once a month (depending on use) to prevent grease build-up and other food deposits.

A clean and well maintained appliance prevents the risk grease fires. Reference the GRILL MAINTENANCE AND SAFETY section.

COOKING GRIDS

Before and after each use, clean the cooking grids with a Fire Magic Grill Brush (sold separately). Before initial use and periodically, it is suggested that the cooking grids be washed with a mild soap and warm water solution.



Fig. 33-1 Wipe with grain

INTERIOR

THE **BURNER PORTS AND CARRY-OVER PORTS/SLOTS** MUST BE KEPT CLEAN TO ENSURE PROPER IGNITION AND OPERATION.

Remove the burner (see the CHECK BURNER ORIFICES section) and clean the ports and slots as required. Also inspect and clean the burner inlet for insects and nests. A clogged burner can lead to a fire in the bottom of the appliance. A burner maintenance kit is available for purchase, see Table 1.

The inside of the appliance may be cleaned periodically with oven cleaner if desired. Follow the oven cleaner instructions for proper use.

Be careful not to get oven cleaner on the outside surface of the appliance as it can permanently damage the finish. DO NOT use glass cleaner that contains ammonia when cleaning glass surfaces inside of the unit.

EXTERIOR

Stainless steel surfaces when exposed to temperatures produced by the grilling process will change color. The stainless steel will change color from silver to brown and blue. This can be removed by using stainless steel cleaner.

Clean your appliance by first using stainless steel grill cleaner to remove grease and dirt. Always wipe with the grain (See Fig. 33-1). Next, apply stainless steel polish and wipe down using polish wipes to restore the stainless steel color. **To clean glass surfaces (if applicable), use a quality brand glass cleaner only, not any of the cleaners mentioned above.**

If your appliance is installed in a seaside (salt air) or poolside (chlorine) location, it will be more susceptible to corrosion and must be maintained/cleaned more frequently. Do not store chemicals (such as chlorine or fertilizer) near your stainless steel appliance.

Due to the nature of stainless steel, surface iron oxide deposits may appear. Do not be alarmed – these deposits are removable with stainless steel cleaner through prompt and periodic maintenance. If not attended to promptly, permanent pitting may occur.

By following these recommendations, you will enjoy the beauty and convenience of your appliance for many years to come.

DRIP TRAY

The drip collector allows you to brush or scrape residue from the grill's inner liner into the drip tray. Regular cleaning of the grill's interior with oven cleaner will help prevent grease fires.

After each use, wait for the grill to cool and carefully pull out the drip tray to check it. When a tray liner is nearing full, carefully lift it out of the drip tray, lifting with both hands to keep the tray level until it is safely discarded. Then insert a new drip tray liner (see INSTALLATION - INSTALL THE DRIP TRAY section if needed).

If a tray liner is not installed, carefully remove the drip tray and empty the contents. Replace the tray.

Order more drip tray liners through your local Fire Magic dealer.

Note: The foil tray liner is also useful for setting on burners to cover them and catch drippings directly during rotisserie only cooking.

PROTECTING YOUR APPLIANCE FROM THE WEATHER

An optional cover will protect your appliance when not in use. Allow to cool before covering. Please specify the model number and serial number of your appliance when ordering a cover.

REPLACING HALOGEN BULBS

Your grill is engineered with the conveniences of electrical power for illuminating and igniting the grill.

To replace any oven light, follow the instructions below.

Important: ONLY REPLACE WITH 12V / 10 WATT HALOGEN BULB(S).

WARNING

To protect from potentially sharp sheet metal and glass, wear gloves and safety glasses during this procedure.

1. Turn all burner control knobs to the **OFF** position and shut off the gas supply to the grill at the source (tank valve for propane units or gas line shut-off valve for natural gas units.)
2. Disconnect supply of external electrical power to the grill.

CAUTION: Wait for the grill, oven, lens, light bulb, and fixture to cool before proceeding to the next step.

3. Open the oven lid.

Important: Place one hand directly below the glass lens and prepare to catch it when it is detached.

4. Carefully insert a standard flat head screwdriver or thin plastic spatula between the glass lens and the stainless steel on which the light is mounted and gently pry the glass lens out in such a way that the stainless steel is not scratched (twisting the screwdriver handle, for instance). Catch the lens and set it safely aside.

Note: You may wish to take this opportunity to clean the lens with a standard household window cleaner and then dry it completely.

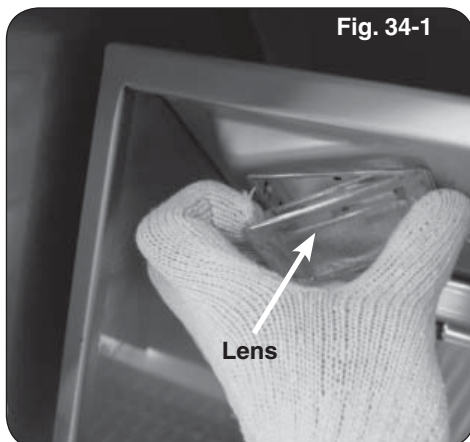

5. Wearing a pair of gloves, reach into the fixture, gently grab the bulb, and pull it straight out of the fixture so that the two pins at the base of the bulb come all the way out.

Important: Bulb is halogen. DO NOT TOUCH with bare hands. Oils from hands drastically reduce bulb life.

Note: It may be helpful to rock the bulb gently backward and forward while pulling it out.

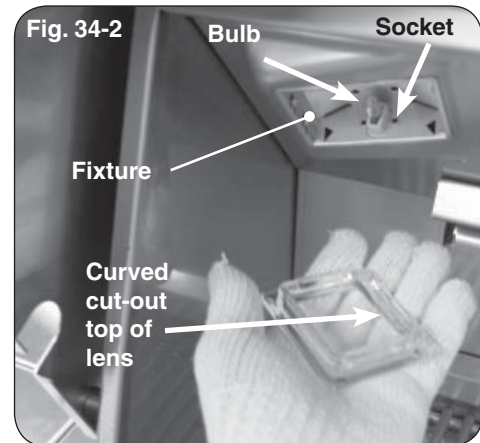

6. Inspect the old bulb for broken glass or filament.

Note: It may be beneficial to test a suspect bulb in one of the other light fixtures known to be working and turn the power back on to be certain the bulb is actually not working.

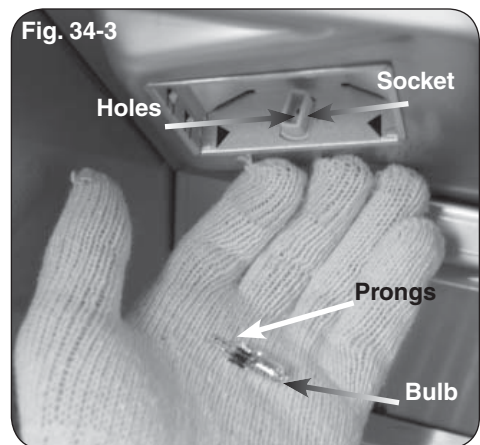

7. Insert the new **12V / 10 watt** halogen bulb into the socket so that both pins slide all the way into the two holes in the bottom of the socket.
8. Place the lens back into the fixture opening with the curved cut-out on the bottom and snap it back into place.

POWER SUPPLY FUSE REPLACEMENT

1. Locate the power supply box inside of the island enclosure (reference the PARTS LIST).
 2. Using a phillips screwdriver, remove the 4 large screws found on the cover of the power supply box (see Fig. 35-1).
 3. Disconnect the power supply cord. Then disconnect the wire harness and ground wire (see Fig. 35-2). Completely remove the box from the enclosure for ease of fuse replacement.
 4. Remove the 4 small screws found on the cover of the power supply box (see Fig. 35-3).
- Note:** The 2 center screws do not need to be removed.
5. Carefully open the box by pulling its cover away. You may need to feed the wire harness into the box to provide enough slack to open on the other end. Then “push in and twist” the fuse holder (red wire), exposing the fuse. See Fig. 35-4.
 6. Replace the fuse accordingly (3AG 2 AMP).

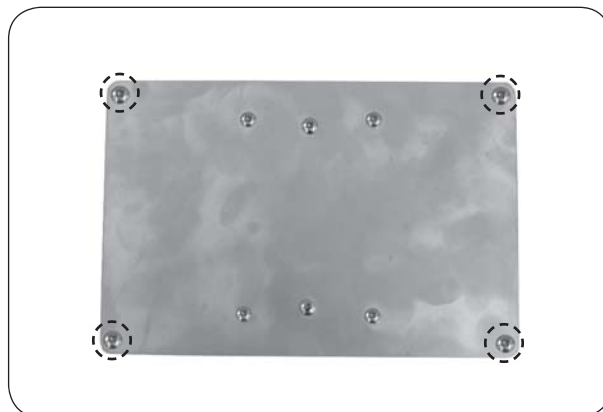

Fig. 35-1 Remove 4 large screws

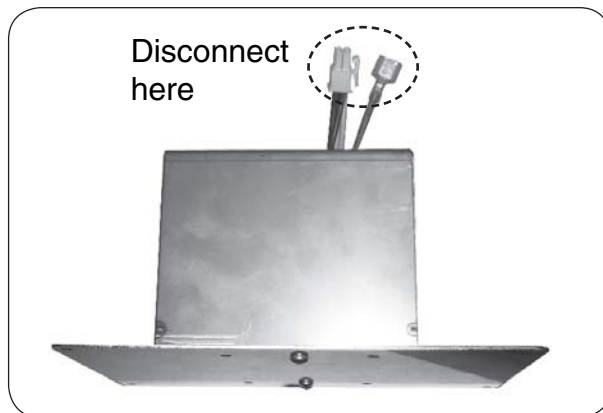

Fig. 35-2 Disconnect wire harness and groundwire (and power cord)



Fig. 35-3 Remove 4 small screws

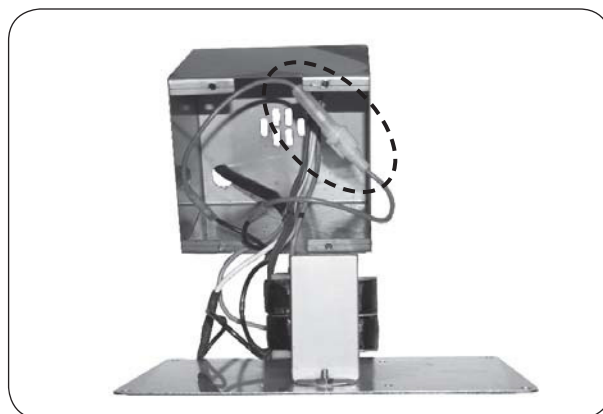

Fig. 35-4 Carefully open box and replace fuse (red wire)

CONVERT GAS TYPE / CHECK BURNER ORIFICES

CAUTION: Make sure the grill is at a safe temperature and isolated from gas and electrical supplies before beginning.

For your safety, exercise caution, and make sure you have adequate hand protection, such as gloves, when handling metal parts.

APPLY CONVERSION LABEL

This grill comes from the factory configured for one type of gas as marked on the label behind the control panel.

When the grill is converted, the label for the new gas (included at original shipping) MUST be filled out and applied next to the existing label mentioned above.

CONVERT REGULATOR

The gas regulator, located behind the control panel, must be set for the type of gas used to fuel the grill. To check the regulator setting, remove the cap in the center of the regulator (Fig. 36-1, A). Holding the cap vertical (see Fig. 36-1, B), the letters at the bottom of the plastic stalk indicate the gas type for which the regulator is currently configured.

If the text on the bottom of the regulator stalk does not match the gas type connected to the grill, remove the stalk from the cap, invert, and replace into center of cap. Replace cap on the regulator, screwing down until snug.

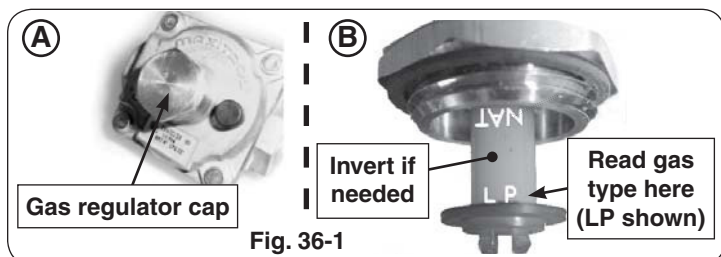

CONVERT GAS ORIFICES

When converting the grill to a different gas type, each burner's orifice must be replaced with the corresponding orifice for the new gas.

See MODEL SPECIFICATIONS TABLE, Table 1 at the beginning of this document to determine the proper orifice sizes for each burner.

See the following sections for details on orifice conversion.

Important: It is critical to the operation of each burner that its orifice be fully inserted into the center of its orifice opening.

WARNING

HAZARDOUS OVERHEATING WILL OCCUR IF A NATURAL-GAS ORIFICE IS USED WITH PROPANE GAS.

CONNECT TO NEW GAS SUPPLY

Plumb the unit as appropriate for the new gas supply. (Additional components may be needed for your specific setup.) **Be sure to leak test at all connections.**

CONVERT/CHECK MAIN BURNER ORIFICES

1. Remove the cooking grid and flavor grid from above the burner you are working on and set them aside.
2. Remove the cotter pin from the left or right rear burner anchoring peg by pulling it straight out of the cotter pin hole using fingers or needle-nose pliers (Fig. 36-2).
3. Lift the back end of the burner out of the anchor peg holes, then move the burner toward the back of the grill to clear the gas inlet and set it aside.

CAUTION: THE BURNER IS HEAVY.

4. Use a $\frac{3}{8}$ " hex nut driver to remove the exposed orifice (Fig. 36-3). Check orifice. If needed, replace it with the correct orifice for the new gas.
5. Replace the burner by first sliding the open cylindrical end of the burner around the orifice, enveloping it and centering on it, then lower the back end anchor pegs into the anchor peg holes.

Note: It is critical to the continued safe functioning of the burner that the orifice is centered and completely inside the burner gas inlet.

6. Reinsert the cotter pin into the right rear burner anchor peg using fingers or needle-nose pliers.
7. Replace the flavor grid and then the cooking grid so that the cut-out section is in front.
8. Repeat these steps for each main burner.

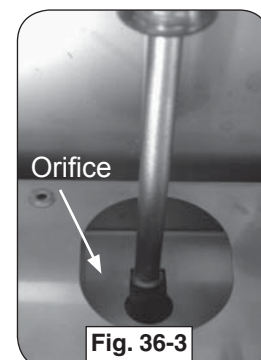
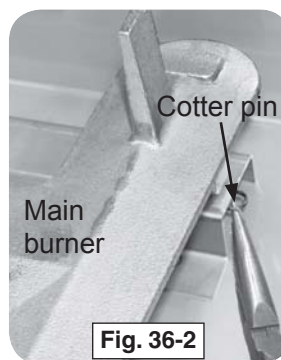

CONVERT/CHECK BACKBURNER ORIFICE

1. Remove the warming rack if installed and set it aside.
2. Remove the backburner cover (lift from the bottom; first upward, then outward. See image on next page).

CONVERT GAS TYPE / CHECK BURNER ORIFICES (cont.)

3. Unfasten the two backburner nuts (found on the left side of the backburner) using a $\frac{1}{4}$ " nut driver and set them aside. See Fig. 37-2.
4. Remove the backburner by lifting the left side outward and to the left. See Fig. 37-3.
5. Use a $\frac{3}{8}$ " hex nut driver to remove the exposed orifice (Fig. 37-4). Check orifice. If needed, replace it with the correct orifice for the new gas.
6. Replace the backburner assembly and fasten the two nuts using a $\frac{1}{4}$ " nut driver.
7. Replace the backburner cover and warming rack.

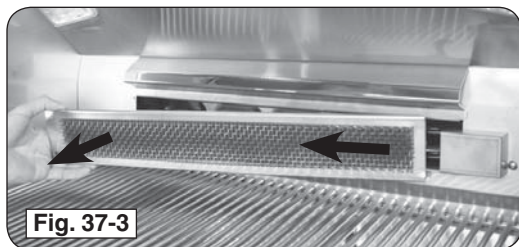
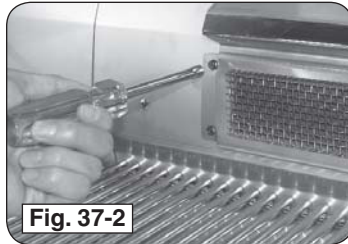
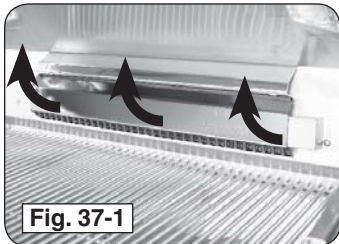

CONVERT/CHECK INFRARED BURNER ORIFICE (IF EQUIPPED)

1. Remove the cooking grid from above the burner.
2. Unscrew both lighting tube hex head screws with a $\frac{3}{8}$ " hex nut driver.
3. Remove the infrared burner by lifting the back of the burner up so that both tabs are freed from their slots, then lift the burner toward the back of the fire box and upward. Set the burner aside.
4. Use a $\frac{3}{8}$ " hex nut driver to remove the exposed orifice. Check orifice. If needed, replace it with the correct orifice for the new gas.
5. Replace the infrared burner by first sliding it over the orifice, then lowering the two tabs under the back of the burner into the slots in the back burner rest.
6. Reattach the lighting tube and replace the grid so that the cut-out section is in front.

BURNER AIR SHUTTER ADJUSTMENT

AIR SHUTTER ADJUSTMENT

Important: Air shutters are preset at the factory based on the gas the grill is built to burn. However, altitude or other local conditions may require air shutter adjustment for proper combustion.

MAIN BURNER(S)

Flames from a properly adjusted main burner with no wind or breeze present will appear fairly steady, consistent, and mostly blue. If the tip of a flame were to turn orange, it should only do so briefly and then become blue again. The flames will appear to burn while touching the burner ports (see Figure 38-1).

If the flames have orange in them and appear to undulate slowly from side to side, or if some of them appear to lift off the burner instead of touching it, then adjust the air shutter, as instructed below.

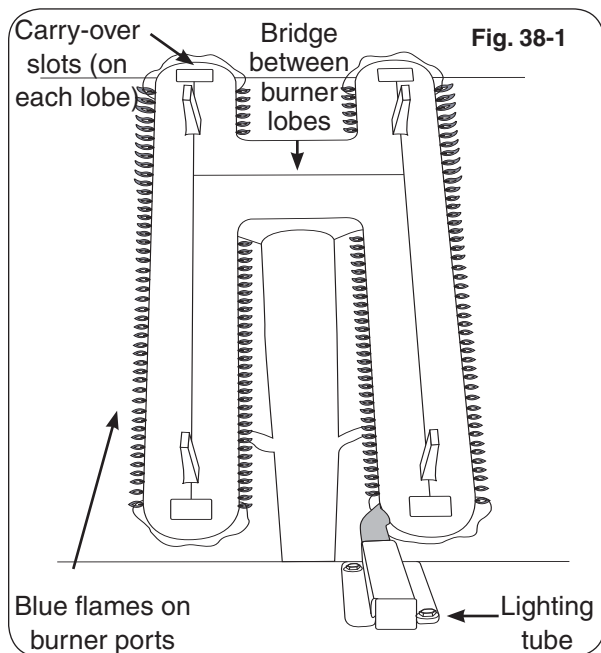

Fig. 38-1

CAUTION: Turn all burner control knobs to the **OFF** position and turn off the gas supply at the source before removing or adjusting a burner.

WARNING

Wait for the burner to be cool or use heavily insulated heat-resistant gloves when handling the burner.

1. Follow the safety precautions and steps for main burner removal in the **CHANGING THE MAIN BURNER ORIFICES** section (steps 1-4).

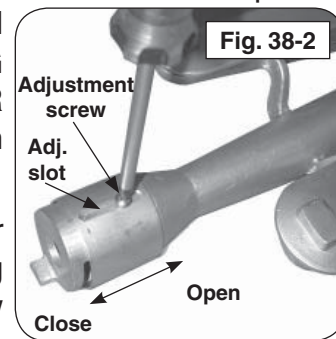

Fig. 38-2

2. Adjust the air shutter opening by loosening the adjustment screw with a screwdriver, then sliding the air shutter backward or forward to open or close the air shutter opening (see Fig. 38-2).

Shutter Setting	Flame Condition
Open too far	Flames shorten and lift off the burner
Ideal setting	Blue flames just touching burner
Closed too far	“Lazy” flames with orange in them

Too large an air shutter opening will allow too much air into the burner, which will cause the flames first to shorten and then to appear to lift up off the ports. For the bottom of the flames to move closer to the ports, close the air shutter more.

If the air shutter opening is too small or closed, the flames will present consistently orange tips and become “lazy,” slowly undulating back and forth.

For propane gas, ideal settings tend to be just slightly open. For natural gas, which generally requires less primary air than propane, the main burner air shutter may be nearly closed.

3. Adjust the air shutter opening and then replace the burner (steps 6-8 in the **CHANGING THE MAIN BURNER ORIFICES** section).
4. Follow the lighting instructions in this manual to light the burner.
5. Repeat steps 1-4 until the flames appear to touch the burner ports, burning fairly steadily and mostly blue (see Fig. 38-1).
6. Repeat this procedure for the other main burner(s), if needed.

CONTROL PANEL REMOVAL

To remove the control panel:

1. Turn the control knobs to the OFF position and turn off the gas supply to the unit.
2. Turn off the master switch and disconnect the power supply from the power source.
3. Pull the control knobs from the stems and set aside.
4. Slowly lift away the lighted bezels to clear the valve stems, and carefully disconnect the wires found on the back of the bezels (use your fingernail). See Fig. 39-1.
5. Remove the drip tray.
6. Using a Phillips screwdriver, unscrew and remove the control panel fastener screws and washers (located on the left and right front face of the control panel). Retain the screws for later re-installation.
7. Carefully open the control panel by lifting and pulling the control panel from the frame, allowing it to rest on the internal chain(s).

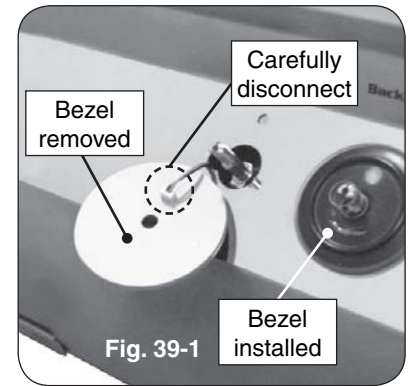

Important: When opening, take caution to not damage any wiring.

8. If wire disconnections are required, reference the wire diagram in the MODEL SPECIFICATIONS section in this instruction manual or the wire diagram label affixed to the inside of the control panel.

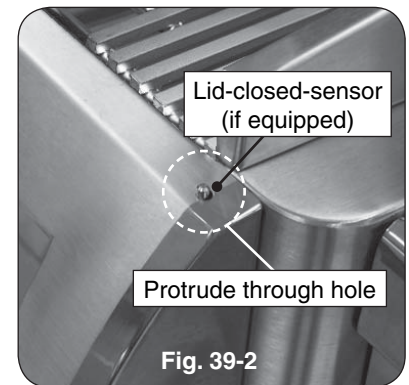

Note: Secure any disconnected wires (coming from the inside of the unit) to prevent them from falling in.

Note: Whenever reconnecting any wires, apply a small amount of dielectric grease to the male connector, then make the connection. This will ensure conductivity and prevent moisture from affecting the contact.

Important: When reinstalling the control panel, set it back over the front lip of the grill so that the lid-closed-sensor plunger protrudes through the hole on the upper right of the control panel (if applicable). See Fig. 39-2.

Important: During reinstallation; prior to opening the gas shut-off valve, be sure the control knobs are in the OFF position.

NOTES PAGE

Please use this page to record any information about your unit that you may want to have at hand.

TROUBLESHOOTING

If you have trouble with the unit, please use this list to identify the problem. By trying one or more of the solutions to the possible cause, you should be able to solve the problem. If this list does not cover your present problem, or if you have other technical difficulties with the unit, please contact your local dealer.

PROBLEM	POSSIBLE CAUSE	CORRECTION
Accessories do not operate	<ol style="list-style-type: none"> 1. Power source not hooked to power supply 2. Master switch is off 	<ol style="list-style-type: none"> 1. Hook external power to unit. 2. Turn master switch on.
Ignition system failure	<ol style="list-style-type: none"> 1. Power source not hooked to power supply 2. Improper air shutter adjustment 3. Ignition wire disconnected 4. Low gas pressure 5. Front carry-over port 6. Blown fuse in power supply box 7. Igniter malfunction 8. Igniter switch malfunction on valve 	<ol style="list-style-type: none"> 1. Hook external power to unit. 2. Adjust air shutters. 3. Plug wires back into ignition switches. 4. Have the gas co. check pressure at unit. 5. Clean burner ports. 6. Replace the fuse. Reference the POWER SUPPLY FUSE REPLACEMENT section. 7. Contact dealer for replacement. 8. Contact dealer for replacement.
Insufficient heat / low flame	<ol style="list-style-type: none"> 1. Burner ports clogged 2. Improper air shutter adjustment 3. Using propane orifice for natural gas 4. Low gas pressure/flame (propane) 5. Low gas pressure/flame (natural) 6. L.P. regulator hose cracked due to age 	<ol style="list-style-type: none"> 1. Clean burner ports. Burner maintenance kit available, see Table 1. 2. Adjust air shutters. 3. Check/change orifices. 4. Shut off all valves, including propane tank, and follow lighting instructions exactly. (See important note* below.) 5. Have the gas co. check pressure at unit. 6. Replace L.P. regulator hose.
Uneven heating	<ol style="list-style-type: none"> 1. Burner ports partially blocked by debris 2. Small spiders or insects in burner 3. Improper air shutter adjustment 	<ol style="list-style-type: none"> 1. Remove burners and clean out ports. 2. Inspect burners and orifices for spider webs or other debris that may block flow. 3. Adjust air shutter.
Thermometer not operating properly	<ol style="list-style-type: none"> 1. Thermometer malfunction 	<ol style="list-style-type: none"> 1. Reset thermometer by turning master switch off then back on.
Interior & knob light(s) not operating	<ol style="list-style-type: none"> 1. Thermometer light switch not functioning 2. Interior or knob light(s) burned out 	<ol style="list-style-type: none"> 1. Reset thermometer by turning master switch off then back on. 2. Contact dealer for replacement.
Burner goes out on LOW	<ol style="list-style-type: none"> 1. Valve "Low" setting needs adjustment 	<ol style="list-style-type: none"> 1. Light burner on HIGH, immediately turn to LOW setting. Remove knob from valve and using a small flat screwdriver, slowly turn the adjustment screw in the stem, a little at a time (30° to 45°), in either direction, until the flame is approximately 1/4" in height from burner ports.
Rotisserie noisy	<ol style="list-style-type: none"> 1. Rotisserie out of balance 	<ol style="list-style-type: none"> 1. Adjust rotisserie counterbalance.

*** Important:** Propane tanks are equipped with a safety shutdown device that may cause low or no gas/flame at the burners if operating and lighting instructions are not followed exactly. **If you suspect the propane tank safety shutoff is in effect:** 1) Shut off all grill valves. 2) Shut off tank valve. 3) Open and close a main burner valve. 4) Open tank valve. 5) Follow the LIGHTING INSTRUCTIONS. Lighting instructions are located in your owner's manual and printed on the unit's metal drip tray. If the problem persists, continue troubleshooting, or contact your local dealer or R. H. Peterson for assistance.

WARRANTY

PETERSON FIRE MAGIC GRILLS AND ACCESSORIES LIMITED WARRANTY

Robert H. Peterson Co. ("RHP") warrants your Fire Magic® grill to be free from defects in material and workmanship.

Fire Magic® cast stainless-steel burners, stainless-steel cooking grids, and stainless-steel housings are warranted for as long as you own your Fire Magic® grill -- **LIFETIME**. (Except as noted below.)

Fire Magic Choice stainless steel tubular burners are warranted for **TWENTY (20) YEARS**.

Fire Magic® cast brass burners, brass valves, inner liners, manifold assemblies, porcelain housings (including ovens and barbecue faces), and backburner assemblies (except ignition parts) are warranted for **FIFTEEN (15) YEARS**.

Fire Magic® Electric Grills, including stainless steel grid, and housings are warranted for **TEN (10) YEARS**.

Fire Magic® Infra-red burners, flavor grids, Charcoal stainless steel grills, and Smokers are warranted for **FIVE (5) YEARS**; except for the charcoal pan, charcoal grid, wood pellet screen, thermometer, and ash tray; which are warranted for **ONE (1) YEAR**.

Fire Magic® sideburners and all other Fire Magic® grill components (except ignition and electronic parts) are warranted for **THREE (3) YEARS**.

Fire Magic® ignition systems (excluding batteries), electronic components (including lights and thermometers), and grill accessories are warranted for **ONE (1) YEAR**.

A COPY OF YOUR SALES SLIP FOR PROOF OF PURCHASE IS REQUIRED

This warranty applies to the original purchaser for products which are installed in the United States or Canada and which are operated and maintained as intended for single family residential usage. This warranty is valid only with proof of purchase, shall commence on the date of purchase, and shall terminate (both as to original and any replacement products) on the anniversary date of the original purchase of the product stated on the above schedules.

This warranty covers defects in material and workmanship. This warranty **does not** cover parts which become defective as a result of negligence, misuse, use not in compliance with the Owner's Manual/Installation Instructions, accidental damage, improper handling, improper storage, improper installation, lack of required routine maintenance (as specified in the Owner's Manual/Installation Instructions), electrical damage, local gas impurities or failure to protect against combustibles. Product must be installed (and gas must be connected) as specified in the Owner's Manual/Installation Instructions by a **qualified professional installer**. Modifications to products which are not specifically authorized will void this warranty. Accessories, parts, valves, remotes, etc. when used must be Peterson products or this warranty is void. Warrantied items will be repaired or replaced at Peterson's sole discretion. This warranty **does not** apply to rust, corrosion, oxidation, or discoloration unless the affected part becomes inoperable.

This warranty **does not** cover labor or labor related charges, except as provided by separate specific written programs from the Peterson Co. All repair work must be performed by a qualified professional service person and requires prior approval of Peterson.

Peterson may require the defective product or part to be returned to the factory to determine the cause of failure. Peterson will pay freight charges if the product or part is determined to be defective. This warranty does not cover breakage in shipment from our (Independent) distributor to its customer if the damage is determined to have occurred during that shipment.

This warranty specifically excludes liability for **indirect, incidental, or consequential** damages. Some states and provinces do not allow the exclusion or limitation of incidental or consequential damages, so the above exclusion may not apply to you. This warranty gives you specified legal rights, and you may have other rights that vary from state to state or province.

For additional information regarding this warranty, or to place a warranty claim, contact the R. H. Peterson dealer where the product was purchased.

**TO REGISTER YOUR PRODUCT ONLINE GO TO: WWW.RHPETERSON.COM,
AND CLICK ON PRODUCT REGISTRATION. THANK YOU FOR YOUR PURCHASE.**

Quality Check			Date: _____			
Burner Orifices	Nat.	L.P.	Leak Test:	_____	Model#:	_____
Main:	_____	_____	Burn Test:	_____	Serial#:	_____
Back:	_____	_____	Gas Type:	<u>Nat. / L.P.</u>	Air Shutter:	_____
Side/Power:	_____	_____			Inspector:	_____
Infrared:	_____	_____				
Other:	_____	_____				